



Operators Manual

**** M-300H ****

Unit Serial No. _____

Monarch Pump

TSP-3 – Serial No. _____

Hydraulic Motor

SNM2/11CI06

Control Valve

Brand FCR51 Serial No. _____

M-300H

These guidelines must be followed or warrant will be voided. Any variation needs to be approved by Surface to Surface.

SET-UP

- Minimum Flow Rate: 10us gpm.
- Maximum Flow Rate: 10.3us gpm.
- Relief Setting: 2250psi.
- Inlet Hose Size: 5/8" minimum
- Outlet Hose Size: 5/8" minimum (*direct to reservoir*)

Specifications on hydraulic oil, operating temperature, and filtration can be found further on in this manual, on the hydraulic motor data sheets.

Any problems or question may be answered by calling Surface to Surface at (800) 567-0978 during normal business hours.

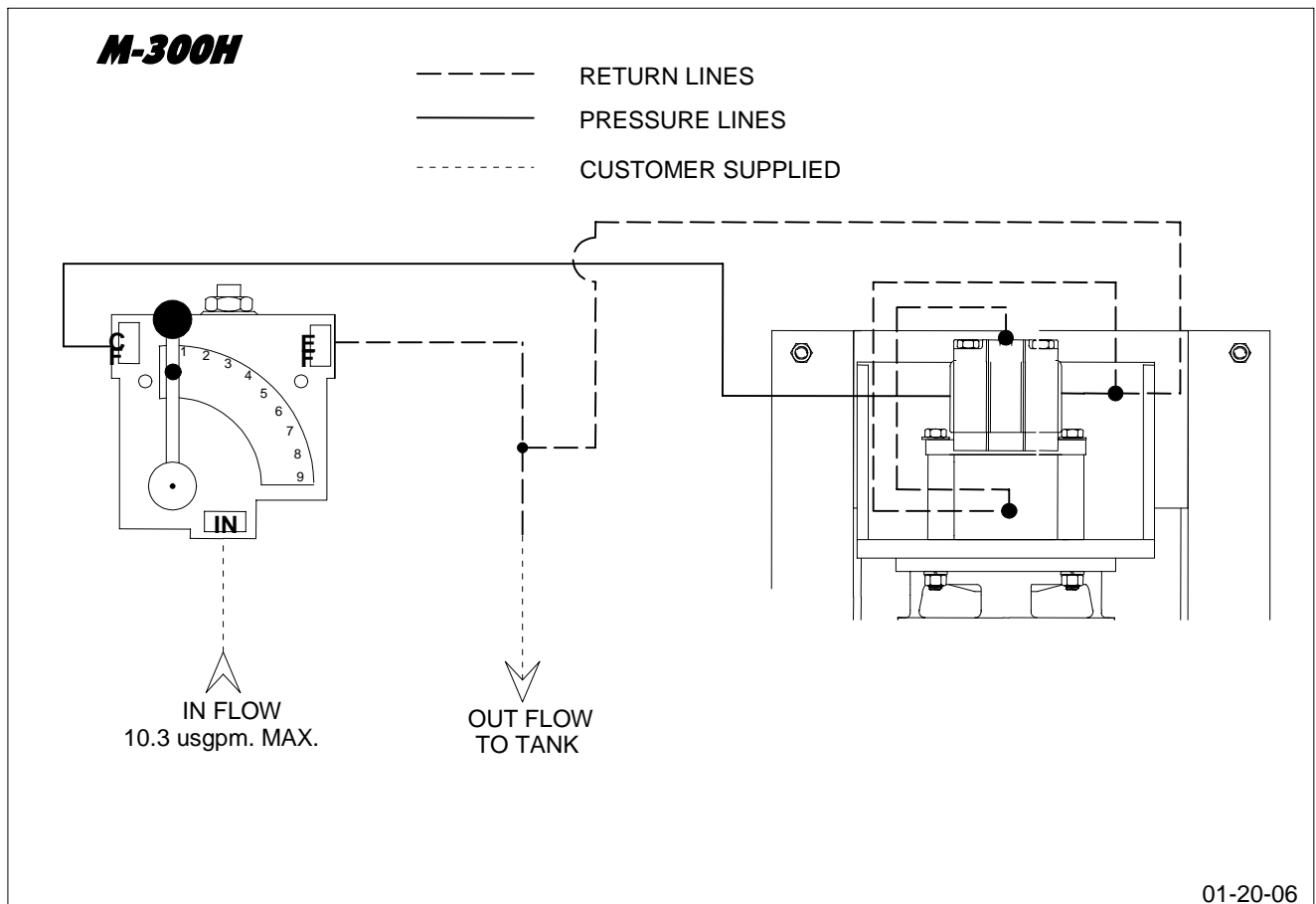



M-300H

CAUTIONS

The following caution statements have been drawn from the instructions in this manual. They have been assembled here for ready reference.

Operating



AVOID high-pressure fluids, as escaping fluids under pressure can penetrate the skin causing serious injury. Relieve pressure before unhooking any hydraulic hoses, lines, or fittings. Tighten all connections before applying pressure. If any fluid is injected into the shin, it must be surgically removed within a few hours by a doctor familiar with this type of injury or gangrene may result.



BEFORE starting the centrifugal pump, make sure the butterfly valve on the pump intake line is open.



BEFORE ENGAGEING THE HYDRAULIC VALVE BE SURE THE PUMP IS PRIMED! This is checked by slowly unscrewing the plug on the top of the centrifugal pump. Water will leak out as the plug is loosened or a visual inspection can be made if the plug is removed. The centrifugal pump **WILL** be damaged if allowed to cavitate or run dry.



WHEN transferring, the flow to the drill rig may reach up to 35 p.s.i. Check the drill rig manufacturers specifications regarding maximum inlet pressures allowed for their pump.



NEVER run the mixing unit with the large tank lid open. If viewing is necessary, open only the small inspection / vent cap. Tank lid is secured with security screws.



THE stone trap (volute) of the centrifugal pump should be cleaned at least weekly and any trash removed.



AVOID allowing foreign material into the Venturi Mixing Tee thru the hopper (i.e.: bag parts, stones, leaves etc) by keeping the valve closed at all times.



NEVER allow fingers or objects such as sticks, screwdrivers, metal bars etc. to enter the tee in an attempt to clear it. Serious personal injury or damage to the butterfly valve will result.



NEVER attempt repairs or disassembly without shutting off the **HYDRAULIC POWER SOURCE**. Serious personal injury will result.



TRAPPED fluid may be present and will spill out when piping, pump front cover or filter/shear is removed.



IMPROPER installation of the mechanical seal will result in leakage and possible damage to the seal. All maintenance, operating and repair of this unit, must be done per the instructions in the operators manual for safety and reliability.



M-300H

CAUTIONS *continued*



CARE must be taken that the coupler gaskets are properly installed or a leak may develop.



IT is imperative that the suction line connections do not leak. The M-300H uses the vacuum created by the venturi jetting to draw fresh water into the reservoir tank.



NEVER leave liquid in the pump casing in freezing weather conditions, damage will result. Follow instruction in this operator manual for winterizing.



IF the intent is to take water from a ditch or pond, it is recommended that a very fine screen be placed over the inlet of the hose, to stop the introduction of foreign material into the M-300H system.

Reservoir Tank



ENTERING the tank is not recommended. Serious injury could result.



AVOID placing objects on the top of the tank (i.e.: bags of bentonite etc.), damage to the tank could result.

Alternative Uses & Moving



CAUTION should be used when considering alternative uses for this equipment. This unit was designed for mixing & blending of bentonite and drilling additives. The manufacturer should be consulted.



WHEN lifting this unit, the polyethylene tank must be empty of fluid or damage may result.



LIFTING lugs or the lift points identified in the skid structure must be used in order to safely lift the unit.

Safety Markings

Hazard and warning markings have been placed at appropriate points on the unit. International symbols have been used, in order to ensure universal understanding of the nature of the hazard. Please comply with all warnings and markings to ensure safe use of the equipment. These include but are not limited to:

- a) Lifting points
- b) Flammable liquids
- c) High temperature areas
- d) Eye protection recommendations
- e) Ear protection recommendations
- f) Dust mask recommendations
- g) Manual requirements
- h) Accessibility restrictions.

M-300H Operators Manual

Congratulations on your acquisition of the patented (U.S. 5,779,355) M-300H Mixing System. You have acquired the fastest and most efficient mixing system manufactured for mixing Bentonite drilling slurry (mud). As a manufacturer of HDD support equipment, we are well aware of the extreme conditions that HDD equipment is exposed to on a daily basis. Surface To Surface strives to overcome these conditions, with better design and manufacturing practices. Please feel free to call our toll free number (1-800-567-0978) if you have any questions or concerns about your M-300H.

Thank you, for choosing the M-300H

The M-300H mixing unit was designed to mix dry or liquid drilling products with clean water, into a slurry. The slurry is continually circulated through the mixing cycle until it reaches the desired consistency. The operator can then transfer the final product to a holding reservoir or directly to the drilling equipment.



WHEN transferring, the flow to the drill rig may reach up to 35 p.s.i. Check the drill rig manufacturers specifications regarding maximum inlet pressures allowed for their pump.

The M-300H mixing unit consists of a 330 u.s. gal. (1250 litre) polyethylene plastic tank, gasoline or hydraulic powered centrifugal pump, filter/shear unit, venturi mixing tee assembly, dry hopper and table, tank internal jet gun and a gasoline, hydraulic, or electric drive. These components are all mounted on a frame type skid, built for lifting or solid mounting. For ease of interpretation, looking at the mixing unit hopper straight on will be considered looking at the front of the unit. Hence the other long side, will be the rear and the ends will be right or left end.



WHEN lifting this unit, the polyethylene tank must be empty of fluid or damage may result.



LIFTING lugs or the lift points identified in the skid structure must be used in order to safely lift the unit.

Care and Maintenance

Polyethylene Plastic Reservoir Tank

Maintenance of this tank is required, but is simple. The tank should be cleaned on a regular basis by opening the drain cap on the tank tee, located at the bottom right end of the tank and or open the customer installed bottom tank drain and rinse the tank with clear water. Residue such as leaves, stones, etc can be removed using a wet /dry vacuum. All tank ports are of a threaded type bung with rubber gaskets. If a leak is noticed between the tank and gasket, the connection can be tightened up by tightening the large nut flange in the direction of the arrows (counter clock wise).



ENTERING the tank is not recommended. Serious injury could result.



NEVER attempt repairs or disassembly without shutting off the unit. Serious personal injury will result.

M-300H

Polyethylene Plastic Reservoir Tank *continued*



AVOID placing objects on the top of the tank i.e.: bags of bentonite etc. Damage to the tank could result.



NEVER run the mixing unit with the large tank lid open. If viewing is necessary, open only the small inspection / vent cap. Tank lid is secured with security screws.

Hydraulic Motor and Centrifugal Pump

Care and maintenance of the hydraulic motor and trash pump are covered in the manufacturer operating manual pages supplied. However, we suggest the following daily checks be carried out prior to using the system. Check the fluid level in YOUR hydraulic reservoir is sufficient. Check the filtering system is working properly. Check that the water suction tee valve is open and the reservoir tank has sufficient liquid to supply the centrifugal pump.



BEFORE starting the centrifugal pump, make sure the butterfly valve on the pump intake line is open.



BEFORE ENGAGEING THE HYDRAULIC VALVE BE SURE THE PUMP IS PRIMED! This is checked by slowly unscrewing the plug on the top of the centrifugal pump. Water will leak out as the plug is loosened or a visual inspection can be made if the plug is removed. The centrifugal pump **WILL** be damaged if allowed to cavitate or run dry.



IMPROPER installation of the mechanical seal will result in leakage and possible damage to the seal. All maintenance, operating and repair of this unit, must be done per the instructions in the operators manual for safety and reliability.



NEVER leave liquid in the pump casing in freezing weather conditions, damage will result.



ADVOID high-pressure fluids, as escaping fluids under pressure can penetrate the skin causing serious injury. Relieve pressure before unhooking any hydraulic hoses, lines, or fittings. Tighten all connections before applying pressure. If any fluid is injected into the shin, it must be surgically removed within a few hours by a doctor familiar with this type of injury or gangrene may result.

Filter / Shear System

The filter / shear system on the M-300H is an integral part of the mixing system and to operate efficiently requires daily cleaning of the stainless steel internal filter /shear. The filter / shear system is a two-piece unit consisting of an outside housing and an internal filter / shear. The filter / shear will trap any debris, such as parts of bags, stones, leaves grass etc. The proper procedure for cleaning the filter shear is to close the suction tee valve from the reservoir tank to the pump, remove the 5 inch Snap Lock coupler at the right end of the filter housing, remove the 3 inch Snap Lock coupler at the discharge port of the centrifugal pump. You will now be able to remove the internal filter / shear from the housing, after the internal filter / shear has been removed, you will see on the end of the filter / shear a cover plate.

M-300H

Filter / Shear System continued

Remove the cover plate and wash out the filter / shear with clear water. Reinstall the cover plate back on the end, reinstall the filter / shear in the housing (*Note the small block on the bottom of the screen, this is placed on the bottom of the filter housing to line up the 5 inch Snap Lock coupler and gasket*) **do-not** clamp the 5 inch coupler until the 3 inch coupler and gasket are properly lined up. After all pieces are correctly lined up, clamp the 5 inch coupler 1st and 3 inch coupler 2nd and reinstall the safety pins.



NEVER attempt repairs or disassembly without shutting off the HYDRAULIC POWER SOURCE. Serious personal injury will result.



TRAPPED fluid may be present and will spill out when piping, pump front cover or filter/shear is removed.



BEFORE ENGAGEING THE HYDRAULIC VALVE BE SURE THE PUMP IS PRIMED! This is checked by slowly unscrewing the plug on the top of the centrifugal pump. Water will leak out as the plug is loosened or a visual inspection can be made if the plug is removed. The centrifugal pump WILL be damaged if allowed to cavitate or run dry.



BEFORE starting the centrifugal pump, make sure the butterfly valve on the pump intake line is open.



CARE must be taken that the coupler gaskets are properly installed or a leak may develop.

Venturi Mixing Tee

The Venturi Mixing Tee is the very heart of this system and requires very little maintenance. However, some parts may wear as a result of the application in time and require replacement. This wear will become evident, when the operator notices a reduction in vacuum. The M-300H is equipped with a pressure wand for clearing obstructions and build-up in the jetting tee. It is recommended that the jetting tee be cleaned with the wash wand after the introduction of material into the hopper.



AVOID allowing foreign material into the Venturi Mixing Tee thru the hopper i.e.: bag parts, stones, leaves etc. by keeping the valve closed at all times.



NEVER allow fingers or objects such as sticks, screwdrivers, metal bars etc. to enter the tee in an attempt to clear it. Serious personal injury or damage to the butterfly valve will result.



IT is imperative that the suction connections do not leak. The M-300H uses the vacuum created by the venturi jetting to draw fresh water into the reservoir tank.



IF the intent is to take water from a ditch or pond, it is recommended that a very fine screen be placed over the inlet of the hose, to stop the introduction of foreign material into the M-300H system.

M-300H

Dry Hopper and Table

The Dry Hopper and Table are used during the initial mixing of the dry material and water. The hopper and table require very little daily maintenance, however care should be used that this unit does not become overloaded. There should never be more than 100 lb. in or on the hopper and table at any time. The hopper and table is not a ladder and should not be climbed on or sat on, damage can result. The wash wand may be used to clean inside the hopper.

The 3 inch butterfly valve must be kept free of dried Bentonite, ice or other buildups to reduce the chance of damage during opening and closing. The valve operates more smoothly if the surfaces are kept damp or wet. All valves are to be opened and closed by hand. **DO NOT FORCE THE VALVE OPEN OR CLOSED**, visually check the valve if a problem occurs!



AVOID allowing foreign material into the Venturi Mixing Tee thru the hopper i.e.: bag parts, stones, leaves etc. by keeping the valve closed at all times.

Pressurized Wash Wand

The wash wand is a maintenance tool used to clear obstruction and build-up in the jetting TEE under the hopper. The wand uses the fluid circulating thru the system and the pressure of the pump to produce a concentrated stream of fluid to aid in dislodging build-up around the jetting nozzle and hopper valve. **DO NOT** use the wash wand as a pry bar or scraper as damage may occur. Let the force of the fluid stream do the work. To use the wash wand properly, first place the wand inside of the hopper, slowly open the valve and direct the fluid stream down into the throat of the hopper. Caution should be taken to keep the wand out of the stream exiting the jetting nozzle, as splash back will occur. After using the wash wand, it should be stored back into its holder.

The wash wand may also be used to obtain a fluid sample for testing purposes. This will give the same sample as the “Drill Fluid Out”. Caution should be taken, as the flow will have to be reduced. To get a good sample, place the wand inside the hopper and open the valve slowly. Let fluid flow out of the wash wand to remove all other fluid in the hose (approx. 20 sec.). Now take the sample, close the valve and return the wash wand back to its holder.



DO NOT position any part of your body over the hopper when cleaning with the wash wand.

Internal Tank Jet Gun

The Internal Jet Gun is located inside the polyethylene plastic reservoir tank, and its function is to keep the slurry product in the tank moving. This function assures the elimination of dead spots in the tank. The “Tank Gun” valve should always be in the open position. The jet gun requires little or no maintenance and will only require attention if the jets become clogged. Flushing the entire system weekly with clear water should eliminate any problems with this piece of the system.

The tank jet gun also acts as relief valve to the system and relieves the pressure spikes caused when the flow to the drill rig or reservoir tank is interrupted.



ENTERING the tank is not recommended. Serious injury could result.

M-300H

OPERATING THE M-300H



Before Starting

- **READ** operators manual for proper starting and running procedures.
- **CHECK** to assure the hydraulic oil reservoir has the proper fluid level for operating.
- **CHECK** to assure the hydraulic filtering system is operating properly.
- **CHECK** to assure the hydraulic variable speed controller is in the stop position.
- **CHECK** to assure the butterfly valve on the pump intake line is open.
- **CHECK** to assure there is sufficient water in the polyethylene plastic reservoir tank, so as not run the centrifugal pump dry.
- **REMOVE** the priming plug, check and/or fill pump casing with water, replace and tighten plug.
- **CHECK** to assure the ball valve on the filter housing marked “Drill Fluid” is closed.
- **CHECK** to assure the ball valve on the filter housing marked “Tank Gun” is open.
- **CHECK** that hopper valve is closed
- **CHECK** that the wash wand valve is closed

Starting hydraulic drive trash pump

- Make sure the hydraulic variable speed control lever is in the stop position (all the way over to the left stop pin).
 - Start **YOUR** hydraulic power unit as per the manufactures instructions and let the hydraulic oil reach the recommended operating temperature.
 - Make sure the centrifugal trash pump is primed and all valves are open / closed as the previous instructions indicated.
 - Do a visual check for hydraulic fluid leaks.
 - The hydraulic variable speed controller may now be **SLOWLY** rotated to the right, approximately 1/4 to start the trash pump, pumping fluid through the system. This will allow the hydraulic oil to fill the lines and come up to speed. At this point you should see fluid entering the 300gal. tank via the top hose.
 - Remember that the system is pumping water under pressure, even when the valve is at a low setting.
 - Gradually rotate the control lever (right) toward the high-speed position and set at the required speed.
- Note:** Whenever high-speed operation is not required, rotate the speed control lever (left) to extend hydraulic motor and trash pump life.*

The Monarch pump used on this unit is self-priming. Priming is not required as long as the pump is kept full of liquid.



BEFORE ENGAGEING THE HYDRAULIC VALVE BE SURE THE PUMP IS PRIMED! This is checked by slowly unscrewing the plug on the top of the centrifugal pump. Water will leak out as the plug is loosened or a visual inspection can be made if the plug is removed. The centrifugal pump WILL be damaged if allowed to cavitate or run dry.



READ CAUTIONS AT FRONT OF MANUAL REGARDING THIS OPERATION!

M-300H

Mixing Operation

- Operate trash pump at high speed.
- Open butterfly valve at bottom of hopper where it joins the venturi mixing tee.
- Introduce the dry or liquid raw material into the hopper.
- Suction created by the venturi mixing tee will draw the raw material into the jet stream for initial mixing.
- Flush jetting tee with wash wand.
- Close the butterfly valve on the hopper to keep debris out of the system.
- Allow the mixing system to run at full speed to circulate the product until the desired consistency is attained.



READ CAUTIONS AT FRONT OF MANUAL REGARDING THIS OPERATION!

Transferring Operation

- On the top of the filter / shear housing of the M-300H you will see a 1 1/2 inch ball valve (1 1/2" NPT.) marked "Drill Fluid".
- A transfer hose with a minimum size of 1 1/2 inch will be attached to the ball valve to carry the finished product to a holding tank or direct to the drill rig.
- Make the necessary connections at the holding tank or drill rig.
- Run the M-300H pump at favorable speed and open the ball valve to allow the flow to the holding tank or drill rig.
- The speed and pressure of the drilling fluid flow, is determined by the trash pump speed.



READ CAUTIONS AT FRONT OF MANUAL REGARDING THIS OPERATION!

Daily Shut Down

- Do not rotate hydraulic control valve suddenly while running at high speed.
- Set the speed control lever at a low speed (1/8-1/4) position and allow the hydraulic motor to run at low speed for 2 to 5 minutes.
- Make sure the butterfly valve under the hopper is closed.
- Move the control lever to the most left position against the stop pin.
- Close the butterfly valve on suction tee to pump.
- Remove filter / shear as described in maintenance section.
- Clean filter / shear as described in maintenance section.



READ CAUTIONS AT FRONT OF MANUAL REGARDING THIS OPERATION!

M-300H

Week End Shut Down

- Pump or drain remaining mixed slurry product out of tank and dispose of it according to local environmental approved practices.
- Make sure “Tank Gun” and “Drill Fluid” valves are open.
- Rinse tank with clear water and then pump through the system, removing as much of the slurry mix in the system as possible. Open the valve on the wash wand to flush with fresh water.
- Drain the remaining water out of the tank (*use the customer installed tank bottom drain valve*) and dispose of it according to local environmental approved practices.
- Remove the drain cap on the suction tee located at the lower right end of tank and allow remaining water to escape from the piping. After draining replace cap.
- Remove centrifugal pump front cover and clean. Replace cover carefully to avoid damage to the seals. DO NOT over tighten Tee handle nuts.
- Make sure “Tank Gun” and “Drill Fluid” and wash wand valves are open.
- Remove filter / shear and clean as described in the maintenance section of this manual.
- Using a wet/dry vacuum, vacuum remaining water and debris from the polyethylene plastic reservoir tank.
- Prolonged periods of storage require extra care of the pump to protect from rusting. Take pump apart to dry and spray with a protective oil film.
- Prolonged periods of storage require engine preparation. See engine operators manual.



READ CAUTIONS AT FRONT OF MANUAL REGARDING THIS OPERATION!

Winter and Freezing Weather Shut Down

- Pump or drain remaining mixed slurry product out of tank and dispose of it according to local environmental approved practices.
- Make sure “Tank Gun” and “Drill Fluid” valves are open.
- Rinse tank with clear water and then pump through the system, removing as much of the slurry mix in the system as possible. Open the valve on the wash wand to flush with fresh water.
- Drain the remaining water out of the tank (*use the customer installed tank bottom drain valve*) and dispose of it according to local environmental approved practices.
- Remove the drain cap on the suction tee located at the lower right end of tank and allow remaining water to escape from the piping. Leave cap off.
- Remove centrifugal pump front cover and clean inside. Leave cover off. This will let remaining moisture to drain.
- Make sure “Tank Gun” and “Drill Fluid” and wash wand valves are open.
- Remove filter / shear and clean as described in the maintenance section of this manual. Leave filter / shear out of housing as this will allow remaining moisture to drain.
- Open the hopper valve and pour in a suitable environmentally friendly anti-freeze until it runs out of the filter / shear housing opened end.
- Shut the hopper valve and pour a suitable environmentally friendly anti-freeze into the hopper until about 2” of fluid cover the valve. This will stop the valve from freezing around the edges.



READ CAUTIONS AT FRONT OF MANUAL REGARDING THIS OPERATION!

M-300H

Self Loading

- If the self-loading feature of The M-300H is required, you will find a 1-1/2 in. NPT port located on the venturi-mixing tee below the hopper. Remove the plug and install a full flow ball valve and a type of quick coupler capable of being capped when not in uses. A non-collapsing hose (*hard hose*) can then be installed.



READ CAUTIONS AT FRONT OF MANUAL REGARDING THIS OPERATION!

NOTES:

OWNER'S MANUAL

TSP SERIES Self Priming Trash Pumps



SAFETY WARNINGS



BEFORE OPERATING OR INSTALLING THIS PUMP, READ THIS MANUAL AND FOLLOW ALL SAFETY RULES AND OPERATING INSTRUCTIONS.

SAFETY CAREFULLY READ THESE SAFETY MESSAGES IN THIS MANUAL AND ON PUMP.

CAUTION

- **DO NOT OPERATE THIS PUMP DRY!**
- Review instructions before operating.
- Wear ear protection to reduce objectionable noise.

WARNING

- Turn off power before servicing.
- If fuel is spilled, avoid creating any source of ignition until the fuel vapors have been cleaned up and removed.

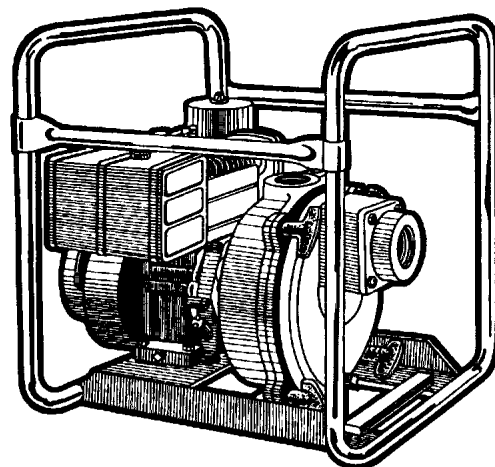

APPLICATION

This pump is suitable for installations where the vertical distance from the pump to the water level does not exceed 25 ft. In off-set

installations, friction losses in the suction pipe must be taken into consideration.

PERFORMANCE

BASED ON 5' SUCTION LIFT.

Pump Model	Pump Size	Solids Handling	Total Head in Feet						
			30	40	50	60	70	80	90
			Capacity in U.S. Gallons per Minute						
TSP 2	2" x 2"	1 1/8"	198	194	180	145	110	75	40
TSP 3	3" x 3"	1 1/2"	318	265	172	98	42		
TSP 4	4" x 4"	2"	616	500	400	280	190	120	45

Pump Model	Total Head in Metres						
	9	12	15	18.5	21.5	23.5	27.5
	Capacity in Litres per Minute						
TSP 2	750	735	680	550	415	285	150
TSP 3	1205	1005	650	370	160		
TSP 4	2330	1890	1515	1060	720	455	170

NOTE: This trash pump can handle pumping stones, leaves, mud and other debris of sizes up to the listed solids handling for the pump and up to 25% of the flow by volume.

INSTALLATION

- (a) **LOCATION:** The pump should be installed in a dry and well ventilated location which provides adequate drainage, room for servicing and protection from freezing temperatures. The pump should be placed on a firm and level foundation. It should be blocked and anchored, or if possible bolted down to prevent creeping due to vibration. Locating the pump as close as possible to the source of liquid supply reduces the friction losses in the suction pipe and provides maximum capacities.

⚠ CAUTION

- Always ensure there is adequate ventilation to prevent asphyxiation.
- (b) **SUCTION HOSE:** Use clean non-collapsible hose of the same diameter as the pump suction piping. Where long lengths of suction hose are used, the suction pipe diameter

should be increased by one size. This will increase the priming time. Check hose connections for leaks and the hose for cuts and cracks. Repair any leaks, cuts or cracks as they reduce pump capacity. The suction pipe must always slope upwards from the liquid source to the pumps to avoid air pockets in the line. In cases where the pump needs to be reprimed often and it is not necessary that maximum capacities be obtained, it is advisable to use a 90° or 45° elbow in the suction line. This enables the pump to prime more quickly and also prevents bending of the hose. In cases where a maximum flow is required over a prolonged period of time, the suction line should be led almost horizontally to the pump. Non-toxic thread compound should be used on all pipe joints and connections should be thoroughly tightened. A strainer should be connected to the bottom end of the suction pipe and it should be well submerged at all times.

OPERATION - PRIMING THE PUMP

⚠ **WARNING:** DO NOT RUN THE PUMP BEFORE PRIMING IT, SINCE THE SEAL AND IMPELLER COULD BE PERMANENTLY DAMAGED.

- (a) **ENGINE:** Check the engine manufacturer's owner's manual supplied with the pump for instructions on engine preparation and start-up procedures. Make sure oil is added to engine crankcase before starting the unit.
- (b) **PRIMING (NON-PRESSURIZED SYSTEM):** Never operate the pump dry as this may damage the pump seal. Remove the priming plug from the top of the pump casing. Fill the pump casing with water through the priming plug. Replace the priming plug and start the engine. The pump should prime in 1/2 to 2 1/2 minutes, depending on the suction hose. If an exceptionally long suction line is used, the water in the casing may become overheated and vapor locked. If this occurs, replace the water in the casing with cold water, using the priming and drain plugs. Continue to prime the pump.

- (c) **PRIMING (PRESSURIZED SYSTEM):** Place a check valve on the discharge line of the pump. Place a pet cock or a ball type air bleeder in place of the priming plug. Another alternative is to install an air bleed line with with gate valve onto the discharge line, see Fig. 1. Open the priming port. Fill the casing with water through the priming port. Replace the plug or bleeder into the priming port. Open pet cock or ball type air bleeder, and start engine. Once a continuous flow of liquid emerges from the bleeder line, priming is complete and the valve on pet cock can be closed off. The pump should prime in 1/2 to 1 1/2 minutes depending on suction lift and the length and diameter of the suction hose. If an exceptionally long suction line is used, the water in the casing may become overheated and vapor locked. If this occurs, replace the water in the casing with cold water using the priming and drain plugs. Continue to prime the pump.

- (d) **UNCLOGGING:** The pump is designed to enable the impeller and volute to be unclogged without disconnecting either suction or discharge hoses. Simply unbolt the four large wing nuts and remove the front cover - suction hose still attached. Remove the volute to expose the impeller. All parts can then be readily cleaned.

- (e) **DRAINING:** Should the pump be subject to freezing temperatures, it will be necessary to drain the pump completely. To drain, remove the drain plug located at the bottom of the front casing and the priming plug and make sure that the drain hold is not choked. After all of the water has been drained out, operate the pump for a few seconds to ensure that the impeller is devoid of water. Make sure that the suction line is also empty.

- (f) **STORAGE OF PUMP:** Drain liquid from pump as explained in the "Draining" section, to prevent freezing. It is recommended that a good rust inhibitor be put in the liquid end to prevent excessive corrosion. Be sure motor is kept dry and covered. When restoring the use of the pump, replace all plugs and make sure all connections are tightly sealed. After a complete check, proceed with the initial prime according to the directions under the section "Priming".

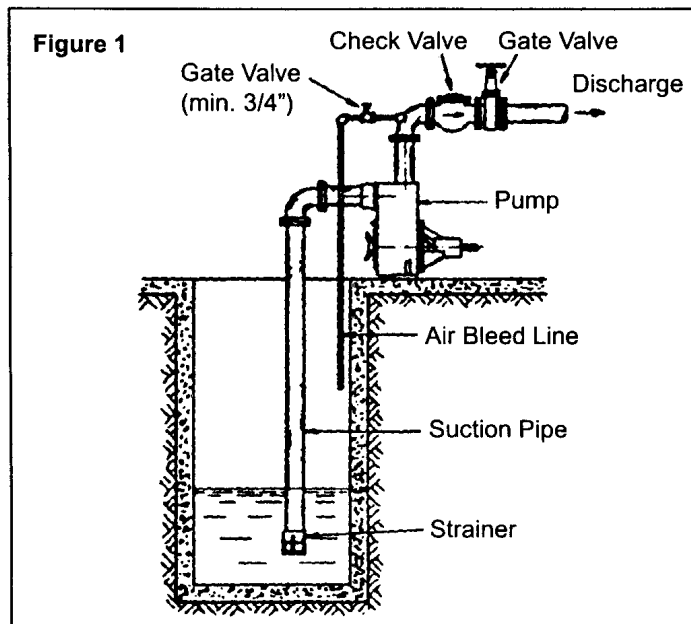

MAINTENANCE

(a) LUBRICATION:

- 1) The pump requires no lubrication.
- 2) For gasoline or diesel engines, refer to the instructions provided by the engine manufacturer.

(b) REPLACING SEALS:

To disassemble:

- 1) Remove four nuts (8) and washers (23) and dismount the front casing (1).
- 2) Remove the volute (7).
- 3) Inspect the seal (11) on the suction side of the volute. It should be replaced if damaged.
- 4) Check 'O' Ring (10) in the groove of the front casing (1). It should be replaced if damaged.
- 5) Unscrew the impeller (2) in a counter-clockwise direction.
- 6) Slip the rotating seal (12) with the sleeve (13) off of the engine shaft.
- 7) Inspect the ceramic seat (12A) fixed in the rear casing (3). If it is worn or damaged, it should be replaced. Unbolt the rear casing from the engine and push the ceramic seat out of its housing in the rear casing from the engine end. Care must be taken so that the shaft is not damaged in the process.

To reassemble:

- 1) Clean all parts thoroughly before reassembly.
- 2) Oil the rubber cup on the ceramic seat (12A) and push

it into the rear casing groove using thumbs only. Make sure that the smooth surface of the ceramic seat faces outwards.

- 3) Assemble the rear casing (3) to the engine being very careful so as not to damage the ceramic seat. Do not forget the lock washers or washer seals when assembling the rear casing to the engine.
- 4) Slide the rotating seal (12) onto the sleeve and then slide the sleeve onto the shaft.
- 5) Screw on the impeller (2).
- 6) Position the volute (7) into the rear casing so that it seats properly into the location diameter of the rear casing. The volute is prevented from rotation by its anti-rotation rib which seats into the slot on the side of the rear casing. It may be necessary to tip the pump rearwards to keep the volute in position until the front casing is in position.
- 7) Slide the seal (11) on the shoulder of the volute.
- 8) Place the 'O' Ring into the groove of the front casing.
- 9) Assemble the front casing with the rear casing.

CAUTION

- Whenever the pump is dismantled and then reassembled, always check to see that the impeller rotates freely within the volute.
- All models have a flinger on the shaft (14). This flinger must not be removed.

TROUBLESHOOTING CHART

PROBLEM	CAUSE
• No discharge	<ol style="list-style-type: none"> 1) Pump not properly primed. 2) Speed too low. 3) Suction lift greater than that for which the pump was designed. 4) Discharge too high. 5) Collapsed or plugged suction hose.
• Reduced capacity and/or head	<ol style="list-style-type: none"> 1) Air leaks in suction line. 2) Clogged impeller. 3) Strainer or foot valve not properly submerged. 4) Excessively worn impeller. 5) Speed too low. 6) Suction lift too great or insufficient NPSH. NPSH, Net Positive Suction Head is the total suction head in feet of liquid (absolute) less the vapor pressure of the liquid in feet (absolute). 7) Partially collapsed or plugged suction line.
• Pump loses prime	<ol style="list-style-type: none"> 1) Air leaks in suction line. 2) Excessive amount of air or gas in liquid. 3) Loose seal (11) due to shrinkage or damage. 4) Suction pipe insufficiently submerged. 5) Suction lift too great. 6) Check if valve may be worn or have dirt lodged between the rubber flap and the valve seat. This prevents the valve from retaining a sufficient amount of water in the casing for proper priming.
• Excessive power consumption	<ol style="list-style-type: none"> 1) Speed too high. 2) Specific gravity or viscosity of liquid too high.
• Noise	<ol style="list-style-type: none"> 1) Suction and discharge piping not properly supported and anchored. 2) Cavitation - check NPSH.

**Toll Free Help Hotline:
1-800-667-1457**

**MONARCH INDUSTRIES
889 Erin Street, P.O. Box 429
Winnipeg, Manitoba, Canada
R3C 3E4**

**Phone: (204) 786-7921
Fax: (204) 889-9120**

LIMITED MONARCH INDUSTRIES WARRANTY

For one year from date of purchase, Monarch Industries will replace or repair for the original purchaser, free of charge, any part or parts, found upon examination by any Monarch Industries Authorized Service Depot or by the Monarch factory, to be defective in material or workmanship or both. Equipment and accessories not manufactured by Monarch Industries are warranted only to the extent of the original manufacturer's warranty. All transportation charges on parts submitted for replacement or repair under this warranty must be borne by the purchaser. For warranty service see your nearest Monarch Industries Authorized Service Depot. THERE IS NO OTHER EXPRESS WARRANTY. IMPLIED WARRANTIES INCLUDING THOSE OF MERCHANTABILITY AND FITNESS FOR A PARTICULAR PURPOSE ARE LIMITED TO ONE YEAR FROM PURCHASE AND TO THE EXTENT PERMITTED BY LAW. LIABILITY FOR CONSEQUENTIAL DAMAGES UNDER ANY AND ALL WARRANTIES ARE EXCLUDED TO THE EXTENT EXCLUSION IS PERMITTED BY LAW. This warranty is an addition to any statutory warranty.

MONARCH INDUSTRIES

PRINTED
IN
CANADA

PRESSURE RATINGS

Sauer-Sundstrand Pumps are designed to operate continuously at rated pressure. In most applications, this maximum pressure should be considered the maximum relief valve setting. Lower operating pressure will extend the life of the unit. For normally expected pump or motor life, normal operating pressure should not exceed one half to two thirds of catalog rating.

MOUNTING

The pump mount/drive should be designed to minimize axial and radial loads on the shaft. When using direct drives a three piece drive coupling provides the ideal arrangement. When using indirect (belt or gear) drive application charts should be consulted to determine permissible load limits and direction of installation.

PIPING

The choice of piping size and installation should always be consistent with maintaining minimum velocity. This will reduce system noise, pressure drops and overheating, thereby adding to cost savings for both the construction and operation of the system.

Inlet piping should be designed to prevent continuous pump inlet vacuums in excess of 4 in. (100 mm) Hg. or 12 in. (300 mm) Hg. during start-up when measured at the inlet port.

A pipe size nomograph is provided at the back of this manual to assist in pipe selection.

RESERVOIR

The reservoir should be designed to accommodate maximum volume changes during all system operating modes and prevent aeration of the fluid as it passes through the tank. Both pump inlet and return lines should be positioned below the reservoir low oil level and be located as far as possible from each other. A baffle plate located between the pump inlet and return line is desirable to cause the oil to contact the outer walls for cooling before it enters the pump.

Reservoirs are normally sized for at least one half the maximum pump flow for adequate oil deaeration.

COOLING

Depending on duty cycle and reservoir/line construction, an oil cooler may be required. This is sized based on typical power losses in the hydraulic circuit. The oil cooler is usually placed in the return line.

CAVITATION

Hydraulic oil used in the majority of systems contains about 10% dissolved air by volume. This air under certain conditions of vacuum within the system is released from the oil causing air bubbles. These air bubbles collapse if subjected to pressure; and this collapse creates erosion of the adjacent metal.

Because of this, it becomes obvious that the greater the air content within the oil, or the greater the vacuum in the inlet line, the more severe will be the resultant erosion.

The main causes of over aeration of the oil are air leaks, particularly on the inlet side of the pump, and flow line restrictions such as inadequate pipe sizes, elbow fittings and sudden changes in flow line cross sectional area.

Providing these defects are avoided; pump inlet pressure and rated speed requirements are maintained; and reservoir size and location is adequate, no cavitation problems should occur with Sauer-Sundstrand pumps and motors.

PRESSURE PROTECTION

The pump, as well as other system components, has pressure limitations. Thus a relief valve must be installed in the system, preferably as close to the pump as possible, to protect it from excessive pressure. If the relief valve is set at or near the maximum pressure rating for the pump, the operating characteristics of the valve should be known so that common relief valve overshoot does not allow system pressure to exceed the pump rating.

CAUTION: Failure to install this relief valve may result in premature unit failure.

SYSTEM NOISE

Pump noise levels generally are not independent of other system components. Other components contribute their own noise level. Response to these noise sources influence the overall system noise. By designing the system to diminish rather than enhance the acoustical characteristics of the potential noise, a quieter system will be achieved. Rigidity, isolation, damping and enclosures are concepts to be utilized in designing quiet systems.

LIFE EXPECTANCY

All Sauer-Sundstrand gear pumps utilize pressure balanced journal bearings which have an oil film maintained between the gear/shaft and bearing surfaces at all times. If this oil film is sufficiently sustained through proper system maintenance and operating limits are adhered to, a high life can be expected.

NOTE: A B-10 type life expectancy number is generally associated with anti-friction bearings and does not exist for journal bearings.

DRIVE CONDITIONS

Most Sauer-Sundstrand gear products are available with SAE standard spline or straight keyed drive shafts for direct or indirect drive applications. A three piece coupling is the preferred method of direct drive, thereby eliminating radial and axial loading.

Rigid spline drives may be used providing the mounting pilot is concentric to the spline within .004 in. T.I.R.

Both concentricity and angular alignment of shafts are important to pump life. Misalignment can induce heavy side loads on bearing and seals, causing premature failure.

Overhung loads caused by gear or belt drive are permissible. Consult the shaft load charts in each gear pump section or contact Sauer-Sundstrand for assistance.

FILTRATION

A wire gauze strainer with a mesh opening of 90 micron (170 mesh) should be incorporated into the pump inlet line from the reservoir. The size of the suction strainer is determined by the limiting suction condition and must be correctly sized and cleaned on a regular basis to prevent cavitation.

A full flow 10 micron filter should be used in the system return line to trap all contaminants before they enter the reservoir.

Since the filter must be changed at regular intervals, the filter housing should be located in an accessible area.

OPERATING TEMPERATURES

Under normal condition, the operating temperature of the system should not exceed 180° F (82° C). Higher operating temperatures are permissible providing Sauer-Sundstrand is consulted about the application. Since system temperature is limited by the life expectancy of the seals, it may be necessary to order special seals for higher temperatures.

CAUTION: Operating at temperatures in excess of limit may cause premature unit failure.

FLUIDS

A mineral based fluid is recommended with additives to resist corrosion, oxidation and foaming. The oil should have the maximum viscosity commensurate with system pressure drop and pump suction levels. The viscosity at any running condition must be between 45 SSU minimum and 250 SSU maximum continuous.

Since the fluid used serves as a system lubricant, as well as transmitting power, careful selection of the fluid is important for proper operation of the unit and satisfactory life of the pump and components.

SUCTION

For maximum pump life, the inlet vacuum should not exceed 4 inches (100 mm) Hg. at the pump inlet. For cold start conditions, vacuum up to 12 inches (300 mm) Hg. is acceptable for short durations.

Both cavitation and the possibility of aeration increase with higher inlet vacuum. In addition, oil film lubrication is disrupted by high inlet vacuum. Both factors, either singularly or combined, may contribute to a decrease in pump life.

MAXIMUM SPEED

Maximum speed is limited by centrifugal gear teeth filling. Unless otherwise specified, maximum rated pump speeds listed in this manual are based on operation at sea level with SAE oil having a viscosity of 130 SSU at 120° F. Speed limits for any particular application may depend on inlet pressure and oil viscosity.

MINIMUM SPEED

Minimum recommended operating speed, at rated pressure, varies from 480 RPM to 1100 RPM depending upon pump size. Minimum speed is limited by volumetric efficiency. If lower than recommended starting or operating speeds are required, contact Sauer-Sundstrand for assistance.

For motors, minimum speeds listed are for continuous operation at rated pressure. Motors may be started from zero speed on drives where torque typically increases with speed. Repeated starts under high load conditions are not recommended. No load start up pressures range from 300 to 600 PSI (20.7 to 41.4 BAR).

INPUT TORQUE RATINGS

The following table gives the maximum torque that is allowed on the input shaft. Non-rigid drives are defined as those that compensate for drive and driven shaft misalignment.

Rigid drives are those that have the pilot and drive element fixed in relation to each other such as plug-in spline drives.

Always insure that the rear pump on a tandem unit does not exceed its non-rigid drive rating.

SERIES	ALLOWABLE SHAFT TORQUE [lbf.in. (Nm)]	
	Non-Rigid Drive	Rigid Drive
TFP 100	260 (29.4)	240 (27.1)
SNP2	690 (78.0)	540 (61.0)
TAP 22/90	2470 (279.1)	1780 (201.1)

CAUTION: Torques in excess of those shown may cause premature input shaft or unit failure.

INSTALLATION OF (CUSTOMER INSTALLED) TANK DRAIN

- Find a suitable location on the tank floor for the drain to be installed, taking into consideration the placement of the unit on a trailer. **LOOK** under the deck for obstructions (cross-members, wiring, and axles, ect.) Allow room for a shut off valve.
- Drill holes into floor of tank using the top (inside) portion of the drain as the template.
- Make sure the holes are free of burrs and both surfaces are clean.
- Install the drain bung as per FIG 1. Note the gaskets are on the inside and outside of the tank.
- Tighten nuts as to slightly squeeze the rubber gaskets.
- Cut a hole into the deck of the trailer or truck for the piping and valve to be installed.
- Install 2" pipe nipple and valve into tank bung with a sealant on the threads. **CAUTION: DO NOT OVERTIGHTEN!**
- The nipple and valve should not extend to far from the tank without a support, as this will cause excess stress on the threads, drain bung and the tank floor.
- Fill with water and check for leaks.

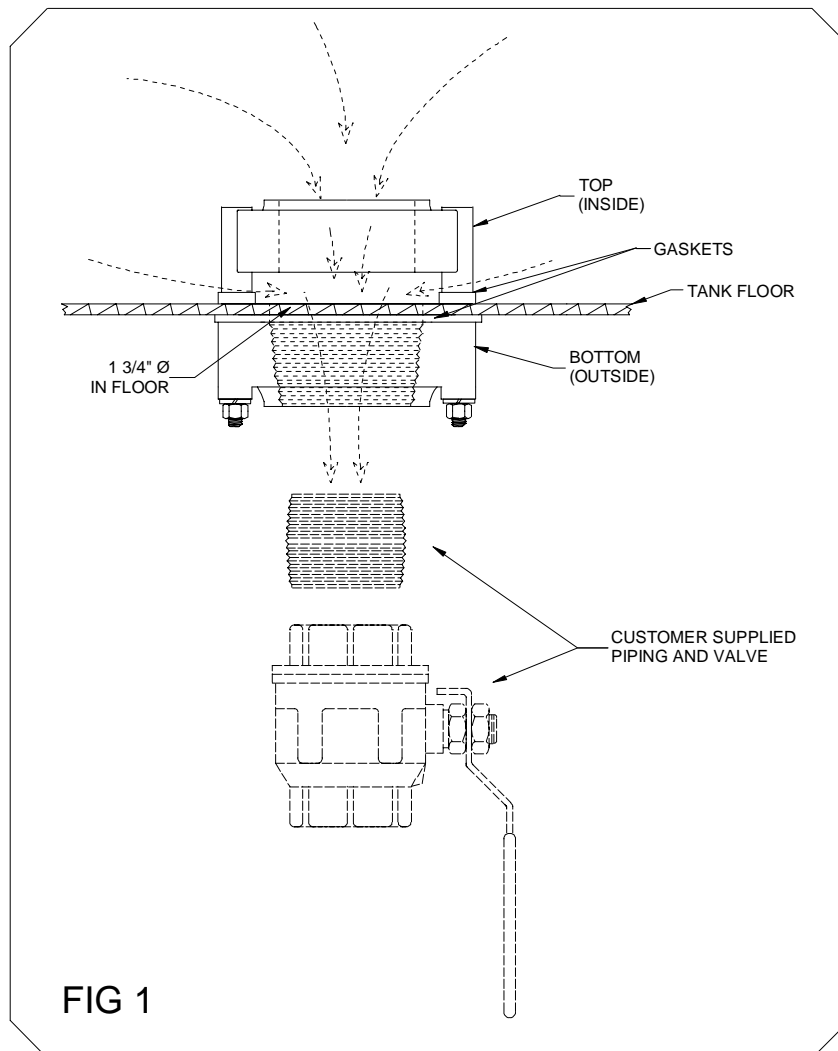

MONARCH TSP SERIES PUMPS REPLACING SEAL

TO DISASSEMBLE

- 1) Remove the T-nuts and washers, remove front cover
- 2) Remove volute
- 3) Inspect the seal on suction side of volute and replace if damaged
- 4) Unscrew impeller in a counter-clockwise direction
- 5) Slip the rotating seal with the sleeve off the engine shaft
- 6) Remove the ceramic seat and o-ring from the pump casing

TO REASSEMBLE

- 1) Clean all parts thoroughly before assembling
- 2) (TSP-4) Remove and lightly coat the o-ring with liquid dish soap, then replace o-ring back onto the ceramic seal.
- 3) (TSP-3) Lightly coat the rubber boot with liquid dish soap.
- 3) Making sure the notch, blue lines or the yellow dots are NOT visible when installed, push the seat into the rear-casing groove, using thumbs only.
- 4) Lightly coat outside of steel sleeve and inside of the rubber boot of the rotating seal with liquid dish soap.
- 5) Clean all faces with lint free cloth.
- 6) Apply a light film of 3 in 1 oil (or equivalent) to both of the seal faces.
- 7) Slide the rotating seal onto the sleeve so face of seal is approx. flush with end of sleeve, taking care that the Silicon carbide seal doesn't fall from its retainer.
- 8) Slide the sleeve (with the seal on it) onto the engine shaft and make sure both seal face are touching each other, then install spring and keeper.
- 9) Replace the shims as required, and screw on the impeller clock-wise. Use anti-seeze on the threads
(Shim impeller 0.010" to 0.020" of clearance between volute)
- 10) Install volute over impeller and check clearance at impeller face.
- 11) Replace front casing making sure not to pinch o-ring, replace washers and tighten T-bolts .
- 12) Make sure pump is primed (wet) before rotating or starting the engine.

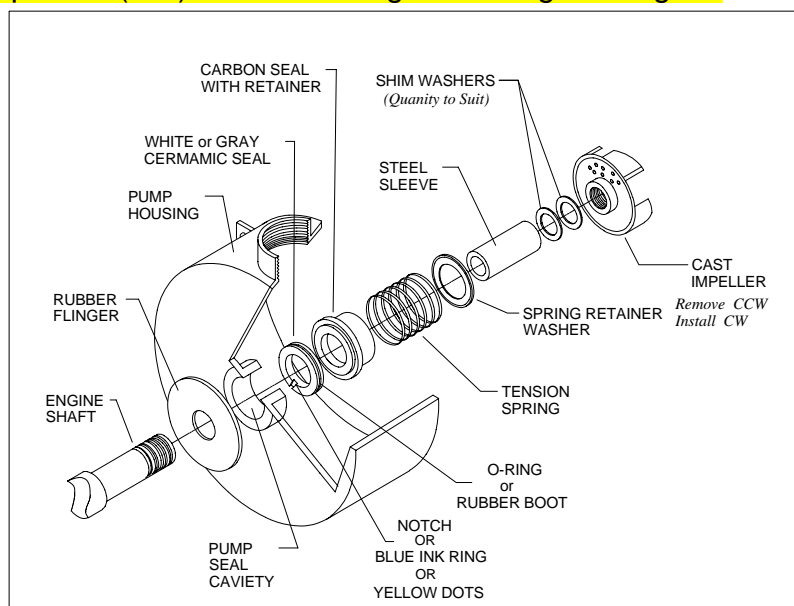

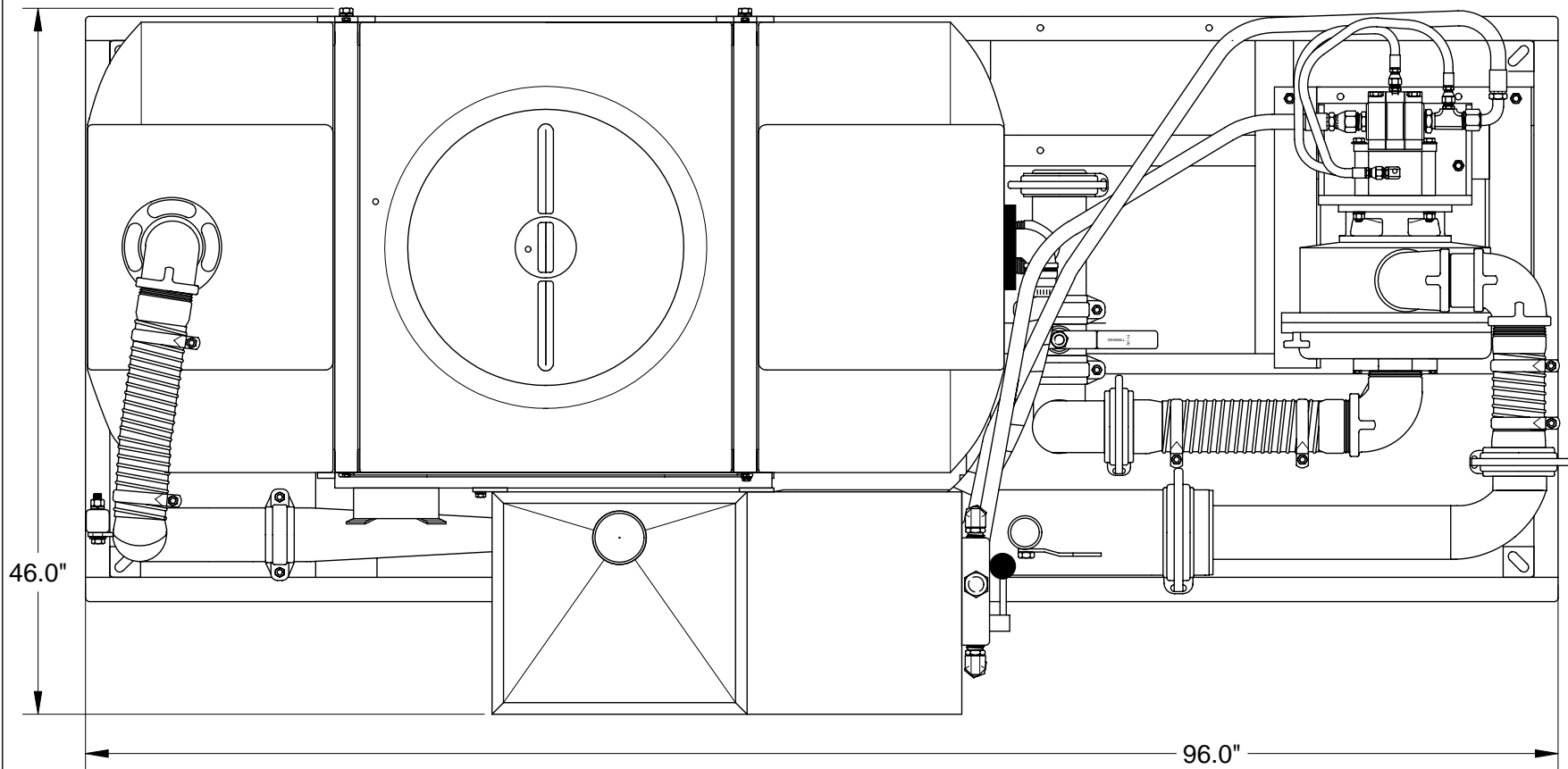

M-300H (Hydraulic)

DRY WEIGHT
1014 lbs.

** Due to our continuing product improvement, specifications are subject to change without notice. **

	
DWR. NUM. M-300H	DATE. 08 / 27 / 99 REV.