



Operators Manual

**** M-750 & M-750D ****

Unit Serial No. _____

Engine

Robin Engine Serial No. _____

Isuzu Engine Serial No. _____

Monarch Pump

TSP-4 – Serial No. _____

Filter Part Numbers

Robin EH 63 Fuel Filter #045-263-65011-A
Robin EH 63 Air Filter #045-263-32610-1
Robin EH 63 Oil Filter #045-248-65801-0

Isuzu 3LB1 Fuel Filter #045-894132947
Isuzu 3LB1 Air Filter #045-897042317
Isuzu 3LB1 Oil Filter #045-294456641

Isuzu 3CB1 Oil Filter #045-5864006320
Isuzu 3CB1 Air Filter #045-P822686
Isuzu 3CB1 Fuel Filter #045-5864007760













M-750 & M-750D

CAUTIONS

The following caution statements have been drawn from the instructions in this manual. They have been assembled here for ready reference.

Operating

-  **BEFORE starting or restarting the engine and centrifugal pump, make sure the butterfly valve on the pump intake line is open.**
-  **BEFORE STARTING OR RUNNING THE ENGINE BE SURE THE PUMP IS PRIMED! This is checked by slowly unscrewing the plug on the top of the centrifugal pump. Water will leak out as the plug is loosened or a visual inspection can be made if the plug is removed. The centrifugal pump WILL be damaged if allowed to cavitate or run dry.**
-  **WHEN transferring, the flow to the drill rig may reach up to 35 p.s.i. Check the drill rig manufacturers specifications regarding maximum inlet pressures allowed for their pump.**
-  **NEVER run the mixing unit with the large tank lid open. If viewing is necessary, open only the small inspection / vent cap. Tank lid is secured with security screws.**
-  **REMEMBER that the system is pumping water under pressure, even when the engine is idling.**
-  **THE stone trap (volute) of the centrifugal pump should be cleaned at least weekly and any trash removed.**
-  **AVOID allowing foreign material into the Venturi Mixing Tee thru the hopper (i.e.: bag parts, stones, leaves etc) by keeping the valve closed at all times.**
-  **NEVER allow fingers or objects such as sticks, screwdrivers, metal bars etc. to enter the tee in an attempt to clear it. Serious personal injury or damage to the butterfly valve will result.**
-  **NEVER attempt repairs or disassembly without shutting off the unit. Serious personal injury will result.**
-  **TRAPPED fluid may be present and will spill out when piping, pump front cover or filter/shear is removed.**
-  **IMPROPER installation of the mechanical seal will result in leakage and possible damage to the seal. All maintenance, operating and repair of this unit, must be done per the instructions in the operators manual for safety and reliability.**

M-750 & M-750D



CAUTIONS *continued*



CARE must be taken that the coupler gaskets are properly installed or a leak may develop.



IT is imperative that the suction line connections do not leak. The M-750 uses the vacuum created by the venturi jetting to draw fresh water into the reservoir tank.



NEVER leave liquid in the pump casing in freezing weather conditions, damage will result. Follow instruction in this operator manual for winterizing.



IF the intent is to take water from a ditch or pond, it is recommended that a very fine screen be placed over the inlet of the hose, to stop the introduction of foreign material into the M-750 system.

Reservoir Tank



ENTERING the tank is not recommended. Serious injury could result.



AVOID placing objects on the top of the tank (i.e.: bags of bentonite etc.), damage to the tank could result.

Alternative Uses & Moving



CAUTION should be used when considering alternative uses for this equipment. This unit was designed for mixing & blending of bentonite and drilling additives. The manufacturer should be consulted.



WHEN lifting this unit, the polyethylene tank must be empty of fluid or damage may result.



LIFTING lugs or the lift points identified in the skid structure must be used in order to safely lift the unit.

Safety Markings

Hazard and warning markings have been placed at appropriate points on the unit. International symbols have been used, in order to ensure universal understanding of the nature of the hazard. Please comply with all warnings and markings to ensure safe use of the equipment. These include but are not limited to:

- a) Lifting points
- b) Flammable liquids
- c) High temperature areas
- d) Eye protection recommendations
- e) Ear protection recommendations
- f) Dust mask recommendations
- g) Manual requirements
- h) Accessibility restrictions.



M-750 & M-750D

Operators Manual

Congratulations on your acquisition of the patented (U.S. 5,779,355) M-750 Mixing System. You have acquired the fastest and most efficient mixing system manufactured for mixing Bentonite drilling slurry (mud). As a manufacturer of HDD support equipment, we are well aware of the extreme conditions that HDD equipment is exposed to on a daily basis. Surface To Surface strives to overcome these conditions, with better design and manufacturing practices. Please feel free to call our toll free number (1-800-567-0978) if you have any questions or concerns about your M-750.

Thank you, for choosing the M-750

The M-750 mixing unit was designed to mix dry or liquid drilling products with clean water, into a slurry. The slurry is continually circulated through the mixing cycle until it reaches the desired consistency. The operator can then transfer the final product to a holding reservoir or directly to the drilling equipment.



WHEN transferring, the flow to the drill rig may reach up to 35 p.s.i. Check the drill rig manufacturers specifications regarding maximum inlet pressures allowed for their pump.

The M-750 mixing unit consists of a 750 u.s. gal. (2839 litre) polyethylene plastic tank, gasoline, diesel, or hydraulic powered centrifugal pump, filter/shear unit, venturi mixing tee assembly, dry hopper and table, tank internal jet gun and a 15u.s. gal (56 litre) gasoline/diesel fuel tank on engine driven models. These components are all mounted on a frame type skid, built for lifting or solid mounting. For ease of interpretation, looking at the mixing unit hopper straight on will be considered looking at the front of the unit. Hence the other long side, will be the rear and the ends will be right or left end.



WHEN lifting this unit, the polyethylene tank must be empty of fluid or damage may result.



LIFTING lugs or the lift points identified in the skid structure must be used in order to safely lift the unit.

Care and Maintenance

Polyethylene Plastic Reservoir Tank

Maintenance of this tank is required, but is simple. The tank should be cleaned on a regular basis by opening the drain cap on the tank tee, located at the bottom right end of the tank and or open the customer installed bottom tank drain and rinse the tank with clear water. Residue such as leaves, stones, etc can be removed using a wet /dry vacuum. All tank ports are of a threaded type bung with rubber gaskets. If a leak is noticed between the tank and gasket, the connection can be tightened up by tightening the large nut flange in the direction of the arrows (counter clock wise).



ENTERING the tank is not recommended. Serious injury could result.



NEVER attempt repairs or disassembly without shutting off the unit. Serious personal injury will result.

M-750 & M-750D

Polyethylene Plastic Reservoir Tank *continued*



AVOID placing objects on the top of the tank i.e.: bags of bentonite etc. Damage to the tank could result.



NEVER run the mixing unit with the large tank lid open. If viewing is necessary, open only the small inspection / vent cap. Tank lid is secured with security screws.

Engine and Centrifugal Pump

Care and maintenance of the engine and pump are covered in the manufacturer operators manuals supplied. However, we suggest the following daily checks be carried out prior to using the system. Check the gasoline or diesel fuel tank is full. Check oil level by removing the oil plug / dip stick, and viewing the level. Check the coolant level and engine air filter (due to environmental conditions). Check that the water suction tee valve is open and the reservoir tank has sufficient liquid to supply the centrifugal pump.



BEFORE starting or restarting the engine and centrifugal pump, make sure the butterfly valve on the pump intake line is open.



BEFORE STARTING OR RUNNING THE ENGINE BE SURE THE PUMP IS PRIMED! This is checked by slowly unscrewing the plug on the top of the centrifugal pump. Water will leak out as the plug is loosened or a visual inspection can be made if the plug is removed. The centrifugal pump **WILL** be damaged if allowed to cavitate or run dry.



IMPROPER installation of the mechanical seal will result in leakage and possible damage to the seal. All maintenance, operating and repair of this unit, must be done per the instructions in the operators manual for safety and reliability.



NEVER leave liquid in the pump casing in freezing weather conditions, damage will result.

Filter / Shear System

The filter / shear system on the M-750 is an integral part of the mixing system and to operate efficiently requires daily cleaning of the stainless steel internal filter / shear. The filter / shear system is a two-piece unit consisting of an outside housing and an internal filter / shear. The filter / shear will trap any debris, such as parts of bags, stones, leaves grass etc. The proper procedure for cleaning the filter shear is to close the suction tee valve from the reservoir tank to the pump, remove the 6 inch Snap Lock coupler at the right end of the filter housing, remove the 4 inch Snap Lock coupler at the discharge port of the centrifugal pump. You will now be able to remove the internal filter / shear from the housing, after the internal filter / shear has been removed, you will see on the end of the filter / shear a cover plate. Remove the cover plate and wash out the filter / shear with clear water. Reinstall the cover plate back on the end, reinstall the filter / shear in the housing (*Note the small block on the bottom of the screen, this is placed on the bottom of the filter housing to line up the 6 inch Snap Lock coupler and gasket*) **do-not** clamp the 6 inch coupler until the 4 inch coupler and gasket are properly lined up. After all pieces are correctly lined up, clamp the 6 inch coupler 1st and 4 inch coupler 2nd and reinstall the safety pins.

M-750 & M-750D

Filter / Shear System continued



NEVER attempt repairs or disassembly without shutting off the unit. Serious personal injury will result.



TRAPPED fluid may be present and will spill out when piping, pump front cover or filter/shear is removed.



BEFORE STARTING OR RUNNING THE ENGINE BE SURE THE PUMP IS PRIMED! This is checked by slowly unscrewing the plug on the top of the centrifugal pump. Water will leak out as the plug is loosened or a visual inspection can be made if the plug is removed. The centrifugal pump WILL be damaged if allowed to cavitate or run dry.



BEFORE starting or restarting the engine and centrifugal pump, make sure the butterfly valve on the pump intake line is open.



CARE must be taken that the coupler gaskets are properly installed or a leak may develop.

Venturi Mixing Tee

The Venturi Mixing Tee is the very heart of this system and requires very little maintenance. However, some parts may wear as a result of the application in time and require replacement. This wear will become evident, when the operator notices a reduction in vacuum. The M-750 is equipped with a pressure wand for clearing obstructions and build-up in the jetting tee. It is recommended that the jetting tee be cleaned with the wash wand after the introduction of material into the hopper.



AVOID allowing foreign material into the Venturi Mixing Tee thru the hopper i.e.: bag parts, stones, leaves etc. by keeping the valve closed at all times.



NEVER allow fingers or objects such as sticks, screwdrivers, metal bars etc. to enter the tee in an attempt to clear it. Serious personal injury or damage to the butterfly valve will result.



IT is imperative that the suction connections do not leak. The M-750 uses the vacuum created by the venturi jetting to draw fresh water into the reservoir tank.



IF the intent is to take water from a ditch or pond, it is recommended that a very fine screen be placed over the inlet of the hose, to stop the introduction of foreign material into the M-750 system.



M-750 & M-750D

Dry Hopper and Table

The Dry Hopper and Table are used during the initial mixing of the dry material and water. The hopper and table require very little daily maintenance, however care should be used that this unit does not become overloaded. There should never be more than 100 lb. in or on the hopper and table at any time. The hopper and table are not a ladder and should not be climbed on or sat on, damage can result. The wash wand may be used to clean inside the hopper.

The 4 inch butterfly valve must be kept free of dried Bentonite, ice or other buildups to reduce the chance of damage during opening and closing. The valve operates more smoothly if the surfaces are kept damp or wet. All valves are to be opened and closed by hand. **DO NOT FORCE THE VALVE OPEN OR CLOSED,** visually check the valve if a problem occurs!



AVOID allowing foreign material into the Venturi Mixing Tee thru the hopper i.e.: bag parts, stones, leaves etc. by keeping the valve closed at all times.

Internal Tank Jet Gun

The Internal Jet Gun is located inside the polyethylene plastic reservoir tank, and its function is to keep the slurry product in the tank moving. This function assures the elimination of dead spots in the tank. The “Tank Gun” valve should always be in the open position. The jet gun requires little or no maintenance and will only require attention if the jets become clogged. Flushing the entire system weekly with clear water should eliminate any problems with this piece of the system.

The tank jet gun also acts as relief valve to the system and relieves the pressure spikes caused when the flow to the drill rig or reservoir tank is interrupted.



ENTERING the tank is not recommended. Serious injury could result.



M-750 & M-750D

OPERATING THE M-750



Before Starting

- **READ** engine operators manual for proper starting and running procedures.
- **CHECK** to assure the engine coolant level is correct. Refer to the operator manual supplied by the engine manufacturer.
- **CHECK** to assure the engine oil level is correct. Refer to the operator manual supplied by the engine manufacturer.
- **CHECK** to assure the air filter is clean (replace if necessary).
- **CHECK** to assure the gasoline or diesel fuel tank is full and the shut off valve is open.
- **CHECK** to assure the butterfly valve on the pump intake line is open.
- **CHECK** to assure there is sufficient water in the polyethylene plastic reservoir tank, to not run the centrifugal pump dry.
- **REMOVE** the priming plug, check and/or fill pump casing with water, replace and tighten plug.
- **CHECK** to assure the ball valve on the filter housing marked “Drill Fluid” is closed.
- **CHECK** to assure the ball valve on the filter housing marked “ Tank Gun” is open.
- **CHECK** that hopper valve is closed
- **CHECK** that the wash wand valve is closed

Starting The Gasoline Engine

- Make sure the gasoline shut off valve located under the gas tank is open.
- Pull the speed control tee handle 1/3 of the way out, towards the high-speed position.
- If the engine is cold or the ambient temperature is low, close the choke fully, by pulling the knob out.
- If the engine is warm or the ambient temperature is high, set the choke to half-way, or keep it fully open by leaving the knob pushed in.
- Turn the key switch to the start position. Do not operate the electric starter continuously for more than 5 seconds, even if the engine does not start. If the engine fails to start, turn the key to the run position and wait for about 10 seconds before retrying.
- After starting the engine, gradually open the choke until fully open. Do not fully open the choke lever immediately when the engine is cold or the ambient temperature is low, or the engine may stop.
- After the engine starts, set the speed control lever at the low speed position and warm it up for a few minutes.
- Remember that the system is pumping water under pressure, even when the engine is idling.
- Gradually pull the speed control lever toward the high-speed position and set at the required speed. *Note: Whenever high-speed operation is not required, slow the engine to down by moving the speed control lever to save fuel and extend engine life.*

The Monarch pump used on this unit is self-priming. Priming is not required as long as the pump is kept full of liquid.



BEFORE STARTING OR RUNNING THE ENGINE BE SURE THE PUMP IS PRIMED! This is checked by slowly unscrewing the plug on the top of the centrifugal pump. Water will leak out as the plug is loosened or a visual inspection can be made if the plug is removed. The centrifugal pump WILL be damaged if allowed to cavitate or run dry.



READ CAUTIONS AT FRONT OF MANUAL REGARDING THIS OPERATION!



M-750 & M-750D

Starting The Diesel Engine

- Make sure the fuel shut off valve located under the diesel tank is open.
- Pull the speed control tee handle 1/3 of the way out, towards the high-speed position.
- Insert the key in the key switch and turn the key clockwise to the DRIVE position only and, make sure that the meters and or warning lamps are actuated.
- If the engine is cold or the ambient temperature is low, pre-heating will be required.
- Turn the key switch counter-clockwise to the PRE-HEAT position in order to heat the glow plugs on the engine.
- A pre-heat time of approximately 5 seconds is required until the control resistance coil becomes red.
- Now turn the key switch clockwise to the START position, to engage the electric starter.
- Do not engage the electric starter for more than 10 seconds. If the engine can not be started at this first attempt, turn the key switch counter-clockwise back to the off position, and wait approximately 30 seconds before pre-heating and trying again.
- After the engine starts, set the speed control lever at a lower speed position and warm it up for 10 minutes.
- Check that all the meters are functional and or the indicator warning lamps are off.
- Remember that the system is pumping water under pressure, even when the engine is idling.
- Gradually pull the speed control lever toward the high-speed position and set at the required speed.

Do not use starting "aids" in the air intake system. Such aids can cause immediate engine damage.

Note: Whenever high-speed operation is not required, slow the engine to down by moving the speed control lever to save fuel and extend engine life.

The Monarch pump used on this unit is self-priming. Priming is not required as long as the pump is kept full of liquid.



BEFORE STARTING OR RUNNING THE ENGINE BE SURE THE PUMP IS PRIMED! This is checked by slowly unscrewing the plug on the top of the centrifugal pump. Water will leak out as the plug is loosened or a visual inspection can be made if the plug is removed. The centrifugal pump WILL be damaged if allowed to cavitate or run dry.



READ CAUTIONS AT FRONT OF MANUAL REGARDING THIS OPERATION!



M-750 & M-750D

Mixing Operation

- Operate engine at high speed.
- Open butterfly valve at bottom of hopper where it joins the venturi mixing tee.
- Introduce the dry or liquid raw material into the hopper.
- Suction created by the venturi mixing tee will draw the raw material into the jet stream for initial mixing.
- Flush jetting tee with wash wand.
- Close the butterfly valve on the hopper to keep debris out of the system.
- Allow the mixing system to run at full speed to circulate the product until the desired consistency is attained.



READ CAUTIONS AT FRONT OF MANUAL REGARDING THIS OPERATION!

Transferring Operation

- On the top of the filter / shear housing of the M-750 you will see a 2 inch ball valve (2" NPT.) marked "Drill Fluid".
- A transfer hose with a minimum size of 2 inch will be attached to the ball valve to carry the finished product to a holding tank or direct to the drill rig.
- Make the necessary connections at the holding tank or drill rig.
- Run the M-750 pump at favorable speed and open the ball valve to allow the flow to the holding tank or drill rig.
- The speed and pressure of the drilling fluid flow, is determined by the engine speed.



READ CAUTIONS AT FRONT OF MANUAL REGARDING THIS OPERATION!

Daily Shut Down

- Set the speed control lever at the low speed position and allow the engine to run at low speed for 5 to 10 minutes.
- Make sure the butterfly valve under the hopper is closed.
- Turn the key switch to the STOP position. Do not stop engine suddenly while running at high speed.
- Close the fuel valve located under the gasoline / diesel tank.
- Close the butterfly valve on suction tee to pump.
- Remove filter / shear as described in maintenance section.
- Clean filter / shear as described in maintenance section.



READ CAUTIONS AT FRONT OF MANUAL REGARDING THIS OPERATION!



M-750 & M-750D

Week End Shut Down

- Pump or drain remaining mixed slurry product out of tank and dispose of it according to local environmental approved practices.
- Make sure “Tank Gun” and “Drill Fluid” valves are open.
- Rinse tank with clear water and then pump through the system, removing as much of the slurry mix in the system as possible. Open the valve on the wash wand to flush with fresh water.
- Drain the remaining water out of the tank (*use the customer installed tank bottom drain valve*) and dispose of it according to local environmental approved practices.
- Remove the drain cap on the suction tee located at the lower right end of tank and allow remaining water to escape from the piping. After draining replace cap.
- Remove centrifugal pump front cover and clean. Replace cover carefully to avoid damage to the seals. DO NOT over tighten Tee handle nuts.
- Make sure “Tank Gun” and “Drill Fluid” and wash wand valves are open.
- Remove filter / shear and clean as described in the maintenance section of this manual.
- Using a wet/dry vacuum, vacuum remaining water and debris from the polyethylene plastic reservoir tank.
- Prolonged periods of storage require extra care of the pump to protect from rusting. Take pump apart to dry and spray with a protective oil film.
- Prolonged periods of storage require engine preparation. See engine operator manual.



READ CAUTIONS AT FRONT OF MANUAL REGARDING THIS OPERATION!

Winter and Freezing Weather Shut Down

- Pump or drain remaining mixed slurry product out of tank and dispose of it according to local environmental approved practices.
- Make sure “Tank Gun” and “Drill Fluid” valves are open.
- Rinse tank with clear water and then pump through the system, removing as much of the slurry mix in the system as possible. Open the valve on the wash wand to flush with fresh water.
- Drain the remaining water out of the tank (*use the customer installed tank bottom drain valve*) and dispose of it according to local environmental approved practices.
- Remove the drain cap on the suction tee located at the lower right end of tank and allow remaining water to escape from the piping. Leave cap off.
- Remove centrifugal pump front cover and clean inside. Leave cover off. This will let remaining moisture to drain.
- Make sure “Tank Gun” and “Drill Fluid” valves and wash wand valve are open.
- Remove filter / shear and clean as described in the maintenance section of this manual. Leave filter / shear out of housing as this will allow remaining moisture to drain.
- Open the hopper valve and pour in a suitable environmentally friendly anti-freeze until it runs out of the filter / shear housing opened end.
- Shut the hopper valve and pour a suitable environmentally friendly anti-freeze into the hopper until about 2” of fluid cover the valve. This will stop the valve from freezing around the edges.



READ CAUTIONS AT FRONT OF MANUAL REGARDING THIS OPERATION!



M-750 & M-750D

Self Loading

- If the self-loading feature of The M-750 is required, you will find a 2 inch NPT port located on the venturi-mixing tee below the hopper. Remove the plug and install a full flow ball valve and a type of quick coupler capable of being capped when not in uses. A non-collapsing hose (*hard hose*) can then be installed.



READ CAUTIONS AT FRONT OF MANUAL REGARDING THIS OPERATION!

NOTES:

OWNER'S MANUAL

TSP SERIES Self Priming Trash Pumps



SAFETY WARNINGS



BEFORE OPERATING OR INSTALLING THIS PUMP, READ THIS MANUAL AND FOLLOW ALL SAFETY RULES AND OPERATING INSTRUCTIONS.

SAFETY CAREFULLY READ THESE SAFETY MESSAGES IN THIS MANUAL AND ON PUMP.

CAUTION

- **DO NOT OPERATE THIS PUMP DRY!**
- Review instructions before operating.
- Wear ear protection to reduce objectionable noise.

WARNING

- Turn off power before servicing.
- If fuel is spilled, avoid creating any source of ignition until the fuel vapors have been cleaned up and removed.

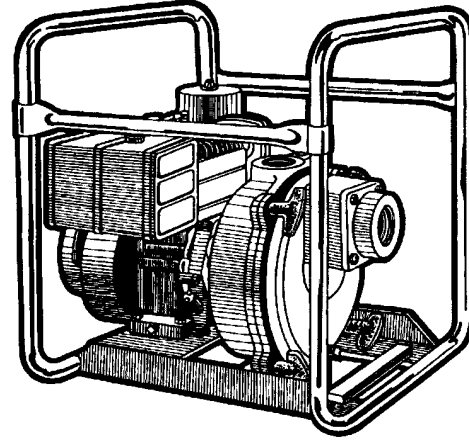

APPLICATION

This pump is suitable for installations where the vertical distance from the pump to the water level does not exceed 25 ft. In off-set

installations, friction losses in the suction pipe must be taken into consideration.

PERFORMANCE

BASED ON 5' SUCTION LIFT.

Pump Model	Pump Size	Solids Handling	Total Head in Feet						
			30	40	50	60	70	80	90
			Capacity in U.S. Gallons per Minute						
TSP 2	2" x 2"	1 1/8"	198	194	180	145	110	75	40
TSP 3	3" x 3"	1 1/2"	318	265	172	98	42		
TSP 4	4" x 4"	2"	616	500	400	280	190	120	45

Pump Model	Total Head in Metres						
	9	12	15	18.5	21.5	23.5	27.5
	Capacity in Litres per Minute						
TSP 2	750	735	680	550	415	285	150
TSP 3	1205	1005	650	370	160		
TSP 4	2330	1890	1515	1060	720	455	170

NOTE: This trash pump can handle pumping stones, leaves, mud and other debris of sizes up to the listed solids handling for the pump and up to 25% of the flow by volume.

INSTALLATION

- (a) **LOCATION:** The pump should be installed in a dry and well ventilated location which provides adequate drainage, room for servicing and protection from freezing temperatures. The pump should be placed on a firm and level foundation. It should be blocked and anchored, or if possible bolted down to prevent creeping due to vibration. Locating the pump as close as possible to the source of liquid supply reduces the friction losses in the suction pipe and provides maximum capacities.

⚠ CAUTION

- Always ensure there is adequate ventilation to prevent asphyxiation.
- (b) **SUCTION HOSE:** Use clean non-collapsible hose of the same diameter as the pump suction piping. Where long lengths of suction hose are used, the suction pipe diameter

should be increased by one size. This will increase the priming time. Check hose connections for leaks and the hose for cuts and cracks. Repair any leaks, cuts or cracks as they reduce pump capacity. The suction pipe must always slope upwards from the liquid source to the pumps to avoid air pockets in the line. In cases where the pump needs to be reprimed often and it is not necessary that maximum capacities be obtained, it is advisable to use a 90° or 45° elbow in the suction line. This enables the pump to prime more quickly and also prevents bending of the hose. In cases where a maximum flow is required over a prolonged period of time, the suction line should be led almost horizontally to the pump. Non-toxic thread compound should be used on all pipe joints and connections should be thoroughly tightened. A strainer should be connected to the bottom end of the suction pipe and it should be well submerged at all times.

OPERATION - PRIMING THE PUMP

⚠ **WARNING:** DO NOT RUN THE PUMP BEFORE PRIMING IT, SINCE THE SEAL AND IMPELLER COULD BE PERMANENTLY DAMAGED.

- (a) **ENGINE:** Check the engine manufacturer's owner's manual supplied with the pump for instructions on engine preparation and start-up procedures. Make sure oil is added to engine crankcase before starting the unit.
- (b) **PRIMING (NON-PRESSURIZED SYSTEM):** Never operate the pump dry as this may damage the pump seal. Remove the priming plug from the top of the pump casing. Fill the pump casing with water through the priming plug. Replace the priming plug and start the engine. The pump should prime in 1/2 to 2 1/2 minutes, depending on the suction hose. If an exceptionally long suction line is used, the water in the casing may become overheated and vapor locked. If this occurs, replace the water in the casing with cold water, using the priming and drain plugs. Continue to prime the pump.
- (c) **PRIMING (PRESSURIZED SYSTEM):** Place a check valve on the discharge line of the pump. Place a pet cock or a ball type air bleeder in place of the priming plug. Another alternative is to install an air bleed line with with gate valve onto the discharge line, see Fig. 1. Open the priming port. Fill the casing with water through the priming port. Replace the plug or bleeder into the priming port. Open pet cock or ball type air bleeder, and start engine. Once a continuous flow of liquid emerges from the bleeder line, priming is complete and the valve on pet cock can be closed off. The pump should prime in 1/2 to 1 1/2 minutes depending on suction lift and the length and diameter of the suction hose. If an exceptionally long suction line is used, the water in the casing may become overheated and vapor locked. If this occurs, replace the water in the casing with cold water using the priming and drain plugs. Continue to prime the pump.
- (d) **UNCLOGGING:** The pump is designed to enable the impeller and volute to be unclogged without disconnecting either suction or discharge hoses. Simply unbolt the four large wing nuts and remove the front cover - suction hose still attached. Remove the volute to expose the impeller. All parts can then be readily cleaned.
- (e) **DRAINING:** Should the pump be subject to freezing temperatures, it will be necessary to drain the pump completely. To drain, remove the drain plug located at the bottom of the front casing and the priming plug and make sure that the drain hold is not choked. After all of the water has been drained out, operate the pump for a few seconds to ensure that the impeller is devoid of water. Make sure that the suction line is also empty.
- (f) **STORAGE OF PUMP:** Drain liquid from pump as explained in the "Draining" section, to prevent freezing. It is recommended that a good rust inhibitor be put in the liquid end to prevent excessive corrosion. Be sure motor is kept dry and covered. When restoring the use of the pump, replace all plugs and make sure all connections are tightly sealed. After a complete check, proceed with the initial prime according to the directions under the section "Priming".

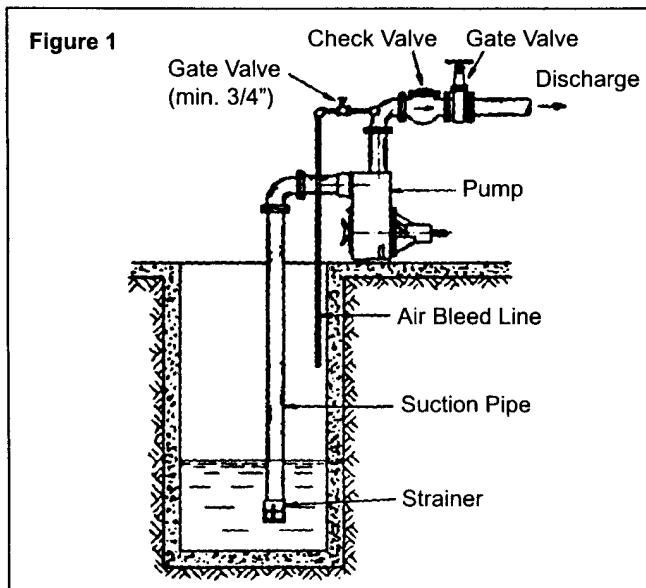

MAINTENANCE

(a) LUBRICATION:

- 1) The pump requires no lubrication.
- 2) For gasoline or diesel engines, refer to the instructions provided by the engine manufacturer.

(b) REPLACING SEALS:

To disassemble:

- 1) Remove four nuts (8) and washers (23) and dismount the front casing (1).
- 2) Remove the volute (7).
- 3) Inspect the seal (11) on the suction side of the volute. It should be replaced if damaged.
- 4) Check 'O' Ring (10) in the groove of the front casing (1). It should be replaced if damaged.
- 5) Unscrew the impeller (2) in a counter-clockwise direction.
- 6) Slip the rotating seal (12) with the sleeve (13) off of the engine shaft.
- 7) Inspect the ceramic seat (12A) fixed in the rear casing (3). If it is worn or damaged, it should be replaced. Unbolt the rear casing from the engine and push the ceramic seat out of its housing in the rear casing from the engine end. Care must be taken so that the shaft is not damaged in the process.

To reassemble:

- 1) Clean all parts thoroughly before reassembly.
- 2) Oil the rubber cup on the ceramic seat (12A) and push

it into the rear casing groove using thumbs only. Make sure that the smooth surface of the ceramic seat faces outwards.

- 3) Assemble the rear casing (3) to the engine being very careful so as not to damage the ceramic seat. Do not forget the lock washers or washer seals when assembling the rear casing to the engine.
- 4) Slide the rotating seal (12) onto the sleeve and then slide the sleeve onto the shaft.
- 5) Screw on the impeller (2).
- 6) Position the volute (7) into the rear casing so that it seats properly into the location diameter of the rear casing. The volute is prevented from rotation by its anti-rotation rib which seats into the slot on the side of the rear casing. It may be necessary to tip the pump rearwards to keep the volute in position until the front casing is in position.
- 7) Slide the seal (11) on the shoulder of the volute.
- 8) Place the 'O' Ring into the groove of the front casing.
- 9) Assemble the front casing with the rear casing.

CAUTION

- Whenever the pump is dismantled and then reassembled, always check to see that the impeller rotates freely within the volute.
- All models have a flinger on the shaft (14). This flinger must not be removed.

TROUBLESHOOTING CHART

PROBLEM	CAUSE
• No discharge	<ol style="list-style-type: none"> 1) Pump not properly primed. 2) Speed too low. 3) Suction lift greater than that for which the pump was designed. 4) Discharge too high. 5) Collapsed or plugged suction hose.
• Reduced capacity and/or head	<ol style="list-style-type: none"> 1) Air leaks in suction line. 2) Clogged impeller. 3) Strainer or foot valve not properly submerged. 4) Excessively worn impeller. 5) Speed too low. 6) Suction lift too great or insufficient NPSH. NPSH, Net Positive Suction Head is the total suction head in feet of liquid (absolute) less the vapor pressure of the liquid in feet (absolute). 7) Partially collapsed or plugged suction line.
• Pump loses prime	<ol style="list-style-type: none"> 1) Air leaks in suction line. 2) Excessive amount of air or gas in liquid. 3) Loose seal (11) due to shrinkage or damage. 4) Suction pipe insufficiently submerged. 5) Suction lift too great. 6) Check if valve may be worn or have dirt lodged between the rubber flap and the valve seat. This prevents the valve from retaining a sufficient amount of water in the casing for proper priming.
• Excessive power consumption	<ol style="list-style-type: none"> 1) Speed too high. 2) Specific gravity or viscosity of liquid too high.
• Noise	<ol style="list-style-type: none"> 1) Suction and discharge piping not properly supported and anchored. 2) Cavitation - check NPSH.

**Toll Free Help Hotline:
1-800-667-1457**

**MONARCH INDUSTRIES
889 Erin Street, P.O. Box 429
Winnipeg, Manitoba, Canada
R3C 3E4**

**Phone: (204) 786-7921
Fax: (204) 889-9120**

LIMITED MONARCH INDUSTRIES WARRANTY

For one year from date of purchase, Monarch Industries will replace or repair for the original purchaser, free of charge, any part or parts, found upon examination by any Monarch Industries Authorized Service Depot or by the Monarch factory, to be defective in material or workmanship or both. Equipment and accessories not manufactured by Monarch Industries are warranted only to the extent of the original manufacturer's warranty. All transportation charges on parts submitted for replacement or repair under this warranty must be borne by the purchaser. For warranty service see your nearest Monarch Industries Authorized Service Depot. THERE IS NO OTHER EXPRESS WARRANTY. IMPLIED WARRANTIES INCLUDING THOSE OF MERCHANTABILITY AND FITNESS FOR A PARTICULAR PURPOSE ARE LIMITED TO ONE YEAR FROM PURCHASE AND TO THE EXTENT PERMITTED BY LAW. LIABILITY FOR CONSEQUENTIAL DAMAGES UNDER ANY AND ALL WARRANTIES ARE EXCLUDED TO THE EXTENT EXCLUSION IS PERMITTED BY LAW. This warranty is an addition to any statutory warranty.

MONARCH INDUSTRIES

PRINTED
IN
CANADA

FOR ENGINE SERVICE GO TO:

www.robinamerica.com

On the left, go to Sales and Service Locator
And follow prompts to find a center near you

Surface to Surface has a limited engine parts inventory. Parts not in stock will have to be ordered.



Model Number Search

- ▶ Advanced Search
- ▶ Engines
- ▶ Generators
- ▶ Pumps
- ▶ New Products

▼ Sales & Service Locator

U.S.A. & Canada
Dealers

U.S.A. & Canada
Engine
Distributors

U.S.A. & Canada
Generator &
Pump
Distributors and
Manufacturer's
Representatives

Latin America
Distributors

Worldwide
Distributors

- ▶ Product Manuals & Downloads
- ▶ About Subaru Robin
- ▶ Press Releases
- ▶ Contact Us
- ▶ Service Center Access
- ▶ Authorized Distributor Access



Subaru Robin Sales & Service Center Locator

Contact an authorized Subaru Robin Sales & Service Center near you for sales, service or parts.

Find Sales & Service Centers in:
Required

Your ZIP or Postal Code:

USA/Puerto Rico: Five digits only.

Canada: First three elements separated from the last three by one space (no hyphens).

Rely on Subaru Robin Reliability!



Engines



Generators



Pumps

FOR ENGINE SERVICE GO TO:

www.isuzuengines.com

*Surface to Surface has a limited engine parts inventory.
Parts not in stock will have to be ordered.*

ISUZU INDUSTRIAL / MARINE
DIESEL ENGINES

Home | Brochure | Warranty Registration | Sitemap



The Power Behind it All Isuzu Vehicle Links

Products | **Distributor Network** | **Service & Support** | **Company** | **Contact Us**

Home > Distributor Network > North America

Locate a Distributor for US and Canada

To find the distributor that supports your area, please either enter your zip code or click on the "Search by Map" button.

Search by Zip Code | **Search by Map**

Locate a distributor by zip code:

distributor network

- » [North America](#)
- » [Worldwide](#)
- » [WW Vehicle Network](#)

Look who's got the Isuzu Advantage?



©2007 Isuzu Motors America Inc.- Privacy Policy

INSTALLATION OF (CUSTOMER INSTALLED) TANK DRAIN

- Find a suitable location on the tank floor for the drain to be installed, taking into consideration the placement of the unit on a trailer. **LOOK** under the deck for obstructions (cross-members, wiring, and axles, ect.) Allow room for a shut off valve.
- Drill holes into floor of tank using the top (inside) portion of the drain as the template.
- Make sure the holes are free of burrs and both surfaces are clean.
- Install the drain bung as per FIG 1. Note the gaskets are on the inside and outside of the tank.
- Tighten nuts as to slightly squeeze the rubber gaskets.
- Cut a hole into the deck of the trailer or truck for the piping and valve to be installed.
- Install 2” pipe nipple and valve into tank bung with a sealant on the threads. **CAUTION: DO NOT OVERTIGHTEN!**
- The nipple and valve should not extend to far from the tank without a support, as this will cause excess stress on the threads, drain bung and the tank floor.
- Fill with water and check for leaks.

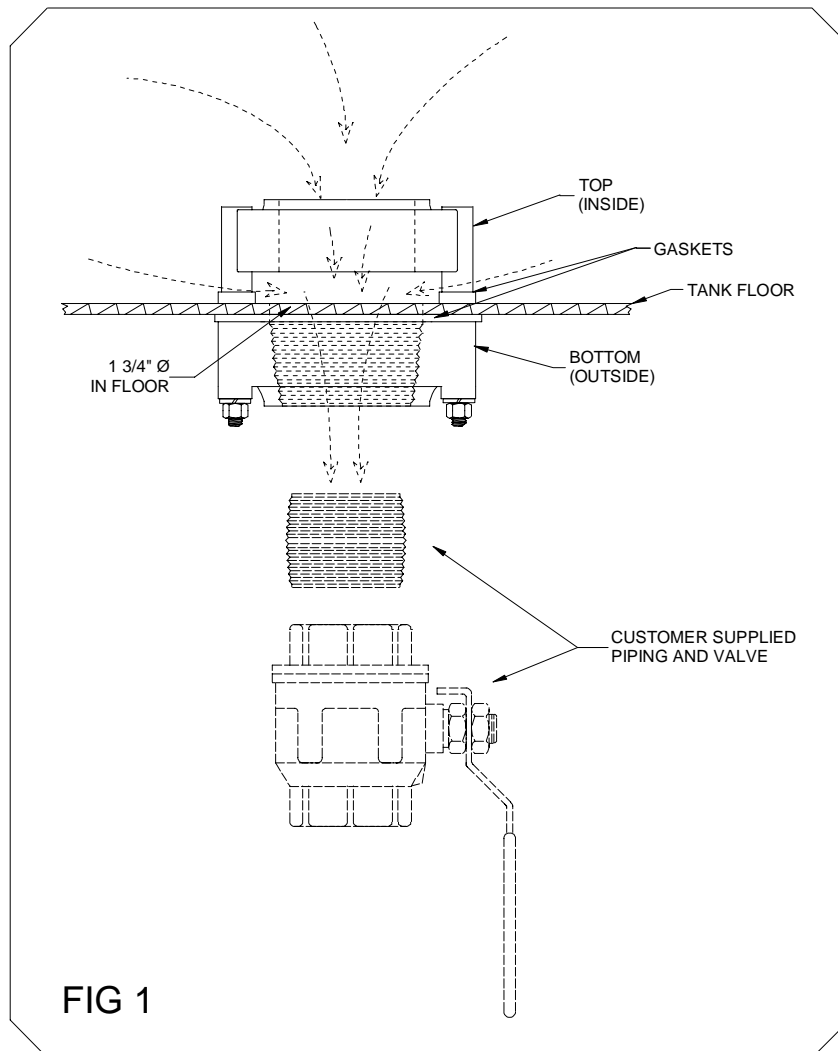

MONARCH TSP SERIES PUMPS

REPLACING SEAL

TO DISASSEMBLE

- 1) Remove the T-nuts and washers, remove front cover
- 2) Remove volute
- 3) Inspect the seal on suction side of volute and replace if damaged
- 4) Unscrew impeller in a counter-clockwise direction
- 5) Slip the rotating seal with the sleeve off the engine shaft
- 6) Remove the ceramic seat and o-ring from the pump casing

TO REASSEMBLE

- 1) Clean all parts thoroughly before assembling
- 2) (TSP-4) Remove and lightly coat the o-ring with liquid dish soap, then replace o-ring back onto the ceramic seal.
- 3) (TSP-3) Lightly coat the rubber boot with liquid dish soap.
- 3) Making sure the notch, blue lines or the yellow dots are NOT visible when installed, push the seat into the rear-casing groove, using thumbs only.
- 4) Lightly coat outside of steel sleeve and inside of the rubber boot of the rotating seal with liquid dish soap.
- 5) Clean all faces with lint free cloth.
- 6) Apply a light film of 3 in 1 oil (or equivalent) to both of the seal faces.
- 7) Slide the rotating seal onto the sleeve so face of seal is approx. flush with end of sleeve, taking care that the Silicon carbide seal doesn't fall from its retainer.
- 8) Slide the sleeve (with the seal on it) onto the engine shaft and make sure both seal face are touching each other, then install spring and keeper.
- 9) Replace the shims as required, and screw on the impeller clock-wise. Use anti-seeze on the threads
(Shim impeller 0.010" to 0.020" of clearance between volute)
- 10) Install volute over impeller and check clearance at impeller face.
- 11) Replace front casing making sure not to pinch o-ring, replace washers and tighten T-bolts .
- 12) Make sure pump is primed (wet) before rotating or starting the engine.

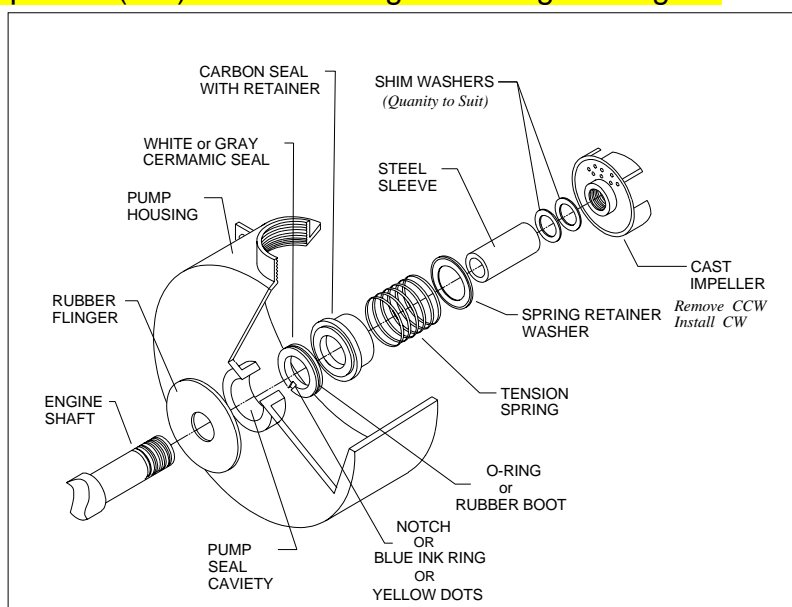

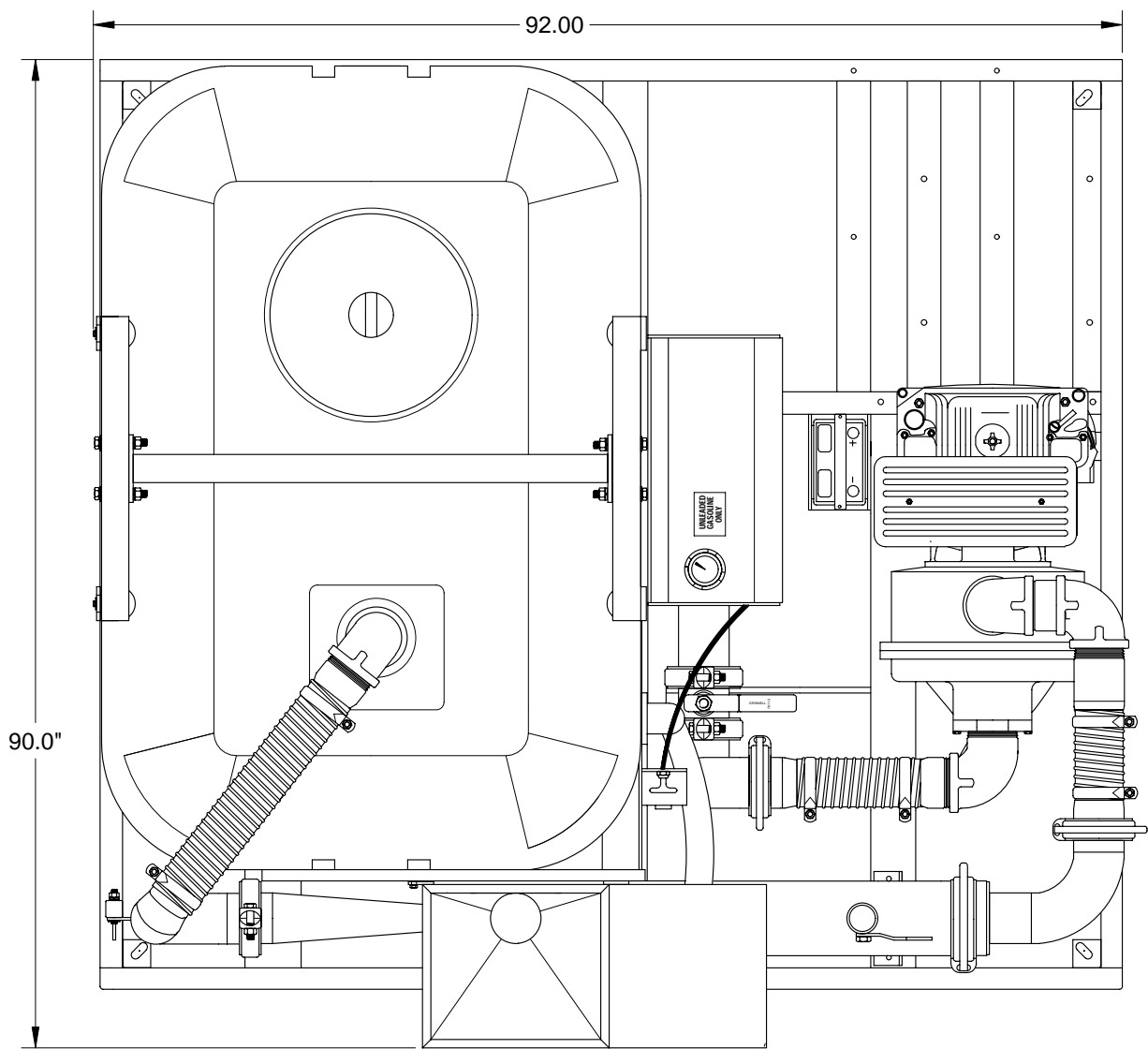

M-750 (Gasoline)

DRY WEIGHT

1900 lbs.

Height 73.0"

** Due to our continuing product improvement, specifications are subject to change without notice.*

DWR. NUM. M-750	DATE. 03 / 11 / 99 REV. 02 / 08 / 02

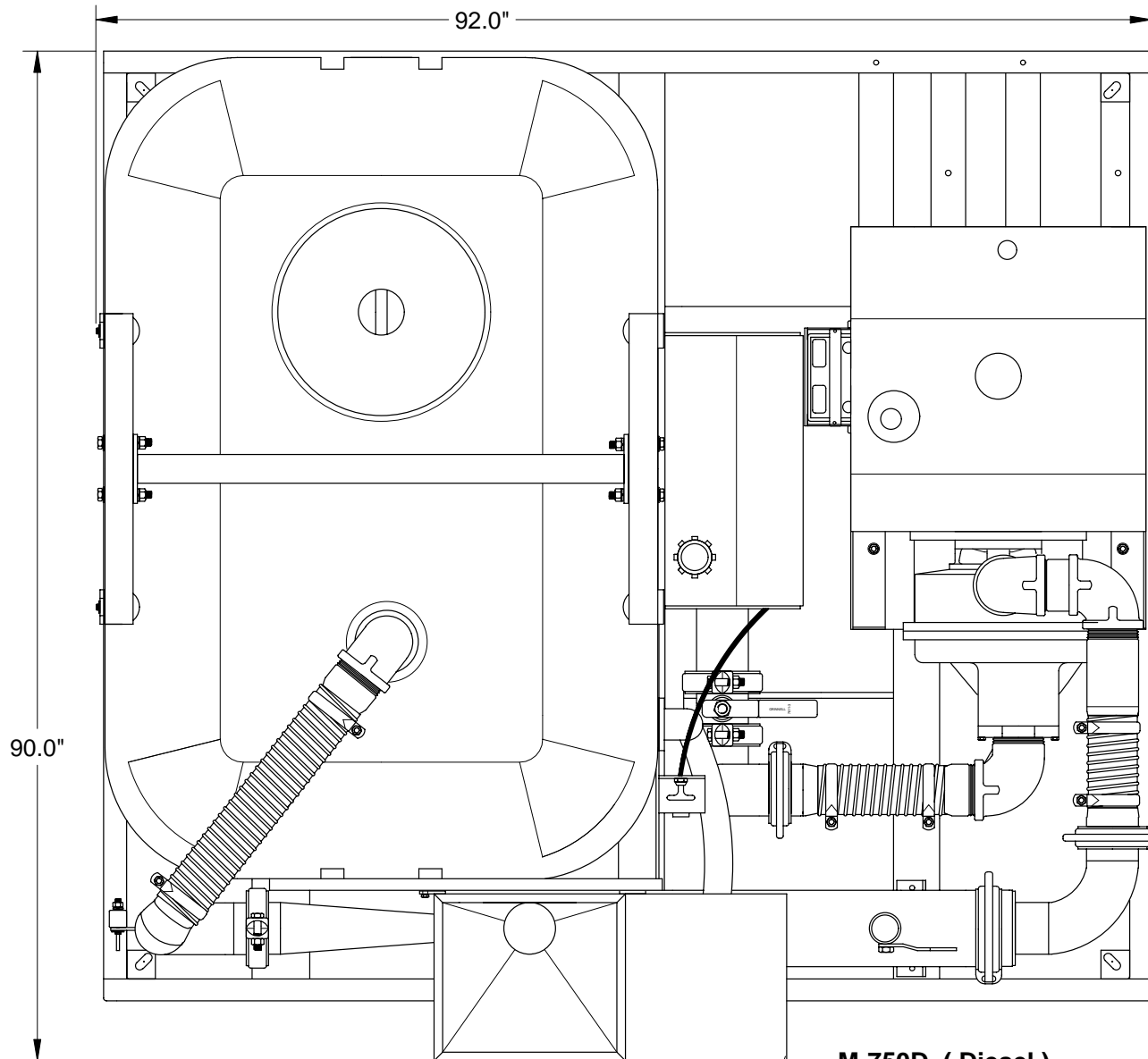

M-750D (Diesel)
DRY WEIGHT
2400 lbs.
 Height 73.0"

** Due to our continuing product improvement, specifications are subject to change without notice. **

<i>Surface to Surface Inc.</i>	
DWR. NUM.	DATE. 03 / 11 / 99
M-750D	REV. 03 / 22 / 02