



**PR-36-S
PIPE ROLLER**

Surface to Surface Inc.

Features and Benefits of the PR-36-S Pipe Roller

The PR-36-S was developed for the contractor who uses a wide range of pipe sizes and varying job conditions. The large flat bottom base makes the unit very stable when used with large diameter pipe. The low profile allows the roller to be used on the ground or raised up on cribbing to a desired ground clearance. The unit does not need to be reconfigured or adjusted (*1 roller, 2 bearings*) to handle different sizes of pipe. The units can be relocated on the site by simply turning over onto the roller and rolled to the next spot. The units can be stacked atop each other for space saving storage. These rollers are very rugged and versatile and can be used for many different applications on the job.

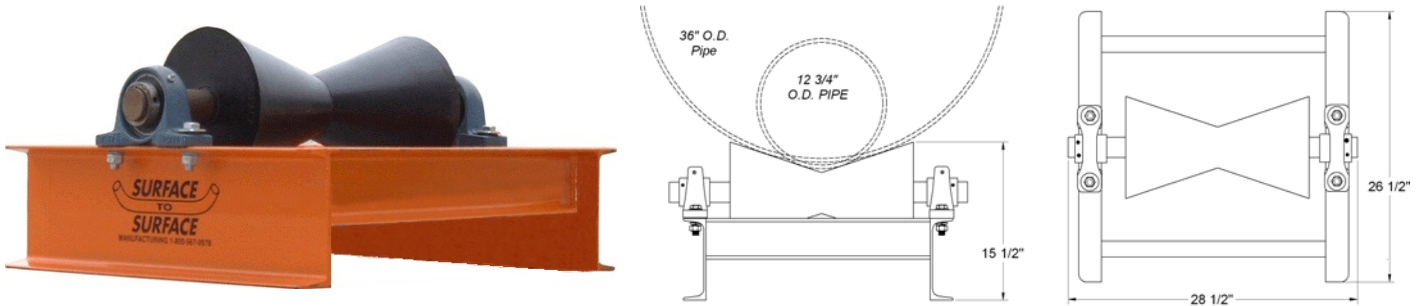

Specifications

Dimensions	26 1/2" x 28 1/2" x 15 1/2" H 673mm x 724mm x 394mm H
Weight	147 lbs. (66.7 kg.)
Load capacity	5000 lbs. (2269.6 kg.)
Pipe range	0-36" O.D. (0-915mm O.D.)
Base frame	8" x 11.5 structural channel
Bearings	2 @ 2" (5600lbs. Static load)
Main Shaft	2" alloy steel (6000lbs.capacity)
Roller material	Solid urethane poured on shaft

Pipe Roller PR-36-S

Benefits

- Large stable base with low profile and stackable for storage and transport.
- Less movement on harder surfaces
- Large capacity for large pipe
- No need to adjust or configure
- Reduced bowing, bending or twisting
- Easy rolling and greaseable
- Less deflection and weight stress
- Resist wear and protects pipe coatings

*** All Specifications Subject to Change Without Notice ***

Check our website for the latest products and specifications
www.stsmixers.com

Surface to Surface Inc.

5150 Forest Road, R.R.#3, Watford, Ontario, N0M 2S0
Tel: 1-800-567-0978

07/09/10